



# NORMALIZATION DOCUMENT AND MONITORING & VERIFICATION GUIDELINES

## Fertilizer Sector



**MINISTRY OF POWER**  
**GOVERNMENT OF INDIA**





# NORMALIZATION DOCUMENT AND MONITORING & VERIFICATION GUIDELINES

## Fertilizer Sector



**MINISTRY OF POWER**  
**GOVERNMENT OF INDIA**



© Bureau of Energy Efficiency, Government of India, March 2015

All rights reserved. No part of this document may be reproduced in any form or by any means without prior permission of Bureau of Energy Efficiency, Government of India.

### **Published by**

Bureau of Energy Efficiency  
Ministry of Power,  
Government of India  
4th Floor, Sewa Bhawan  
R K Puram  
New Delhi -110 066

Developed specifically for Designated Consumers notified under Perform Achieve and Trade (PAT) Program for National Mission for Energy Efficiency (NMEEE)

### **Disclaimer**

This document has been developed after an extensive consultation with a number of experts and stakeholders of the scheme. BEE disclaim any liability for any kind of loss whatsoever, whether special, indirect, consequential, or compensatory, directly or indirectly resulting from the publication, or reliance on this document.

Conceptualized by Media NMEEE

Processed and Printed in India by Viba Press Pvt. Ltd.,  
C-66/3, Okhla Industrial Area, Phase-II, New Delhi-110020  
Tel. : 011-41611300 / 301 Email : vibappl@hotmail.com



# Contents

<b>1. Introduction</b>	<b>1</b>
<b>2. National Mission for Enhanced Energy Efficiency</b>	<b>1</b>
<b>3. Perform, Achieve and Trade (PAT) Scheme</b>	<b>2</b>
<b>4. Background</b>	<b>2</b>
<b>5. Status of Designated Consumer (DCs)</b>	<b>4</b>
5.1 General Rules for Establishing Baseline Values	4
5.2 Grouping of DC's for fixing targets for reduction in SEC	5
<b>6. Normalization factors for the Fertilizer sector</b>	<b>9</b>
6.1. Low capacity utilization	9
6.1.1. Pre-requisites for Normalisation	9
6.1.2. Calculation of normalization factor	9
6.1.3. Supporting data / documentation	10
6.1.4. Calculation of Normalization factor for low capacity utilization	11
6.2. Cold startup of the plant after forced shut down	13
6.2.1. Pre-requisites for Normalization	13
6.2.2. Calculation of normalization factor	13
6.3. Use of naphtha	14
6.3.1. Pre-requisites for Normalization	14
6.3.2. Calculation of normalization factor	14
6.4. Catalyst reduction	15
6.4.1. Pre-requisites for Normalization	15
6.4.2. Calculation of normalization factor	15
6.5. Deterioration in quality of Coal	15
6.5.1. Pre-Requisites for Normalization	15
6.5.2. Calculation of normalization factor	15
6.6. Additional provisions	16



## Part-II

### MONITORING & VERIFICATION GUIDELINES

<b>1. Introduction</b>	19
1.1. Background	19
1.2. Purpose	20
1.3. Definition of M&V	20
1.4. Empanelled Accredited Energy Auditor or Verifier	21
1.4.1. Qualification of Empanelled Accredited Energy Auditor (EmAEA) for Verification and Check-Verification	22
1.4.2. Obligation of Empanelled Accreditor Energy Auditor	22
1.5. Important Documents required for M&V process	23
1.6. Stakeholders	24
<b>2. Broad Roles and Responsibilities</b>	24
2.1. General	24
2.2. Designated Consumer	25
2.3. Empanelled Accredited Energy Auditor (EmAEA)	27
2.4. State Designated Agencies (SDA)	28
2.5. Adjudicator	29
2.6. Bureau of Energy Efficiency	29
2.7. Ministry of Power	30
2.8. Institutional Framework for PAT	30
<b>3. Process &amp; Timelines</b>	31
3.1. Activities and Responsibilities	31
3.2. Process Interlinking	32
3.2.1. Process of Issuance of Escerts	33
3.3. Flow Chart showing verification process (Rules and Act required dates in bold Italics)	34
<b>4. Verification requirement</b>	35
4.1. Guidelines for Selection Criteria of EmAEA by Designated Consumer	35
4.2. Guidelines for Empanelled Accredited Energy Auditor	35
4.3. Guidelines for Verification process	36
4.3.1. Sector Specific Pro-forma	36
4.3.2. Reporting in Sector Specific Pro-forma	37



4.3.3. Verification Process	38
4.3.4. Primary and Secondary source of Documentation	41
<b>5. Understanding Conditions</b>	<b>65</b>
5.1. Specific Issues	66
5.2. Fuel	67
5.3. Normalization Condition and calculation	68
5.4. Normalisation General Issue	70
<b>6. Abbreviations</b>	<b>72</b>
<b>7. Annexure</b>	<b>73</b>
7.1. Annexure I: Thermal Power Station	74
7.2. Annexure II: Steel	79
7.3. Annexure III: Cement	80
7.4. Annexure IV: Fertilizer	86
7.5. Annexure V: Aluminium	103
7.6. Annexure VI: Pulp & Paper	106
7.7. Annexure VII: Textile	129
7.8. Annexure VIII: Chlor Alkali	135



## Tables

Table 1:	Activities and Responsibilities for PAT Cycle I	31
Table 2:	Team Details (Minimum Team Composition)	36
Table 3:	Production and Capacity Utilisation details	41
Table 4:	Major Equipment capacity and Operating SEC	43
Table 5:	Boiler Details (Process and Co-Generation)	44
Table 6:	Electricity from Grid/Others, Renewable Purchase Obligation, Notified Figures	46
Table 7:	Own generation through Captive Power Plants	48
Table 8:	Solid Fuel Consumption	52
Table 9:	Liquid Fuel Consumption	55
Table 10:	Gaseous Fuel Consumption	58
Table 11:	Documents for Quality Parameter	60
Table 12:	Documents related to Environmental Concern, Biomass/Alternate Fuel availability, Project Activities, New Line commissioning, Unforeseen Circumstances	61
Table 13:	Documents related to External Factor	65
Table 14:	Lump Co-Generation treatment	69
Table 15:	Auxiliary Power Consumption Details (a,b,c)	74
Table 16:	Sponge Iron Subsector- Major Product details	80
Table 17:	Section wise Specific Power Consumption Details	83
Table 18:	Mass and Energy balance	84
Table 19:	Clinker Factor calculation	85
Table 20:	Material and Energy balance of Fertilizer sector	86
Table 21:	Material balance of all inputs in Fertilizer sector	89
Table 22:	Section wise Energy Consumption details	103
Table 23:	Section wise Energy Consumption details	104
Table 24:	Voltage Distribution	105
Table 25:	General details required in wood based Pulp and Paper Mills	107
Table 26:	Documents required wood based Pulp and Paper Mills	111
Table 27:	General details required in Agro based Pulp and Paper Mills	115
Table 28:	Document required for Agro based Pulp and Paper Mills	119
Table 29:	General details required in RCF based Pulp and Paper Mills	123
Table 30:	Documents required in RCF based Pulp and Paper	126
Table 31:	Section wise Energy Consumption	130
Table 32:	Section wise Energy Consumption	132
Table 33:	Product Name in Fiber Sun-sector	134
Table 34:	Section wise Energy Consumption	134
Table 35:	Section wise Energy details	135





## Figures

Figure 1:	M&V Documents	23
Figure 2:	Stakeholders	24
Figure 3:	Institutional Framework	30
Figure 4:	Stakeholders Interlinking	32
Figure 5:	Flow Chart of ESCerts issuance	33
Figure 6:	Time Line Flow Chart	34
Figure 7:	Stakeholders Output	39
Figure 8:	Ex-GtG Boundary for Thermal Power Plant	77
Figure 9:	Ex-Coal/Lignite/Oil/Gas based Thermal Power Plant Energy balance diagram	78
Figure 10:	Ex-CCGT Energy balance diagram	79
Figure 11:	Product Mix diagram	81
Figure 12:	Ex-GtG Boundary boundary for Sponge Iron Sub-sector	82
Figure 13:	Figure 14: Ex-GtG boundary for Cement Sector	84
Figure 15:	Fertilizer plant Battery Limit block diagram	91
Figure 16:	Overall Material and Energy balance	94
Figure 17:	Ex- GtG boundary for Aluminium (Refinery sub sector)	104
Figure 18:	Ex- GtG boundary for Aluminium (Smelter sub sector)	105
Figure 19:	Ex- GtG boundary for Aluminium (Cold Sheet sub sector)	106
Figure 20:	Ex- GtG boundary and metering details for Wood based Pulp and Paper Mill	110
Figure 21:	Ex- GtG boundary and metering details for Agro based Pulp and Paper Mill	118
Figure 22:	Ex- GtG boundary for Textile (Spinning sub sector)	131
Figure 23:	Ex- GtG boundary for Textile ( Composite/ Processing sub sector)	133
Figure 24:	Ex- GtG boundary for Textile (Fiber) Sub- sector	135
Figure 25:	Ex- GtG boundary for Chlor-Alkali sector	136



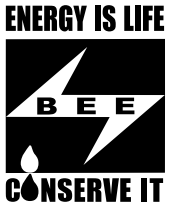

आतंत्र्यक्रमांक  
वर्ष 1 जून 2011

**BUREAU OF ENERGY EFFICIENCY**

(Government of India, Ministry of Power)

वर्ष 1 जून 2011  
वर्ष 1 जून 2011

**Ajay Mathur, Ph.D.**  
Director General

## Foreword

Perform Achieve and Trade (PAT), a flagship initiative under National Mission for Enhanced Energy Efficiency (NMEEE), is a regulatory intervention for reduction of specific energy consumption, with an associated market based mechanism through which additional energy savings can be quantified and traded as ESCerts.

Fertilizer sector is one of the 8 notified energy intensive sectors under which a total of 29 plants are participating in this program. These plants have been mandated to reduce their Specific Energy Consumption (SEC) from baseline year of 2009-2010. It is expected that these plants may save 0.478 million tons of oil equivalent annually by the end of PAT cycle –I.

The publication of “**Normalization Document and M&V Guidelines**” for Fertilizer Sector is an effort to facilitate the DCs to comply with notified PAT rules to participate with the PAT scheme and contribute towards achieving national target of energy savings. This document will also be helpful to all empanelled Accredited Energy Auditors (EmAEAs) and State Designated Agencies (SDAs) in the monitoring and verification process of PAT.

I want to record my appreciation for members of the Sectoral Expert Committee on Fertilizer Sector, chaired by Dr. S. Nand, Dy. Director General, Fertilizer Association of India, Shri Sameer Pandita, Asst. Energy Economist, BEE and Shri VK Goyal, Sector Expert, Shri Vikas Ranjan, Technical Expert, GIZ who worked tirelessly to put together the baseline data, normalization factors and M&V methodology for the sector.

I also compliment the efforts of all participating industrial units towards their endeavor in contributing to the national energy saving targets.

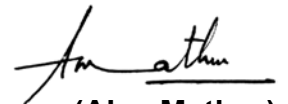
  
(Ajay Mathur)

वर्ष 1 जून 2011, आतंत्र्यक्रमांक  
Save Energy for Benefit of Self and Nation

पता: 4th Floor, Sewa Bhawan, R.K. Puram, New Delhi - 110 066

दूरभाष: 26178316 (1 लाइन) / Direct 26179699 (5 लाइनेस) / QD / Fax : 91 (11) 26178328  
ईमेल: dg-bee@nic.in / वेबसाइट: www.beeindia.in



### Sectoral Expert Committee on Fertilizer

S. No	Name of Member	Designation	
1.	Dr. S.Nand	Deputy Director General, Fertilizer Association of India	Chairman
2.	Shri Manish Tripathi	Ex .Deputy Secretary (Fertilizer), Ministry of Chemicals and Fertilizers, Department of Fertilizer	Nodal officer and Member
3.	Shri Vijay Ranjan Singh	Director( Fertilizers ), Ministry of Chemicals and Fertilizers, Department of Fertilizer	Nodal officer and Member
4.	Shri Rajesh Aggarwal	Director, (Technical) National Fertilizer Limited	Member
5.	Shri KL Singh	Director, (Technical) Indian Farmers Fertilizer Cooperative Limited	Member
6.	Shri VK Goyal	Sector Expert	Invitee

### Technical Sub Committee on Fertilizer

S. No	Name of Member	Designation
1.	Shri Piyush Misra	Deputy General Manager, IFFCO
2.	Shri KM Tandon	Vice President (Fertilizer), Shriram Fertilizers and Chemicals , Kota
3.	Shri SD Pandare	Deputy General Manager (Corporate), Rashtriya Chemicals and Fertilizers Limited, Mumbai
4.	Shri Manish Goswami	Deputy Chief (Technical ) , FAI
5.	Shri VK Goyal	Sector Expert, Fertilizer
6.	Shri Sameer Pandita	Assistant Energy Economist, BEE

### Special Thanks to Team NMEEE

S. No	Name of Member	Designation
1.	Shri Kapil Mohan, IAS	Ex. Deputy Director General, NMEEE
2.	Shri Alok, IAS	Ex Deputy Director General, NMEEE
3.	Shri K.K. Chakarvarti	Ex .Energy Economist
4.	Shri Ashok Kumar	Energy Economist
5.	Shri Sunil Khandare	Energy Economist
6.	Shri Saurabh Diddi	Energy Economist
7.	Shri Sameer Pandita	Assistant Energy Economist, BEE
8.	Shri Arijit Sengupta	Assistant Energy Economist, BEE
9.	Shri Girija Shankar	Assistant Energy Economist, BEE
10.	Smt. Vineeta Kanwal	Assistant Energy Economist, BEE
11.	Shri Ajay Tripathi	Media Manager
12.	Shri KK Nair	Finance and Accounts officer, BEE
13.	Shri A K Asthana	Senior Technical Expert, GIZ
14.	Shri Vikas Ranjan	Technical Expert, GIZ



# 1. Introduction

The National Action Plan on Climate Change (NAPCC) released by the Prime Minister on 30 June, 2008, recognises the need to maintain high economic growth to raise the living standards of India’s vast majority of people and simultaneously reducing their vulnerability to the impacts of climate change.

The National Action Plan outlines eight national missions that represent multi-pronged, long-term, and integrated strategies for achieving key goals to mitigate the impact of climate change. These missions are listed below:

- National Solar Mission
- National Mission for Enhanced Energy Efficiency
- National Mission on Sustainable Habitat
- National Water Mission
- National Mission for Sustaining the Himalayan Ecosystem
- National Mission for a Green India
- National Mission for Sustainable Agriculture
- National Mission for Strategic Knowledge for Climate Change

## 1.1 National Mission for Enhanced Energy Efficiency

The National Mission for Enhanced Energy Efficiency (NMEEE) is one of the eight national missions with the objective of promoting innovative policy and regulatory regimes, financing mechanisms, and business models which not only create, but also sustain, markets for energy efficiency in a transparent manner with clear deliverables to be achieved in a time bound manner. It also has inbuilt provisions for monitoring and evaluation so as to ensure transparency, accountability, and responsiveness. The Ministry of Power (MoP) and Bureau of Energy Efficiency (BEE) were tasked to prepare the implementation plan for NMEEE.

NMEEE spelt out the following four new initiatives to enhance energy efficiency, in addition to the programmes on energy efficiency being pursued. These are:

- **Perform, Achieve and Trade (PAT)**, a market based mechanism to make improvements in energy efficiency in energy-intensive large industries and to make facilities more cost - effective by certification of energy saving that can be traded.

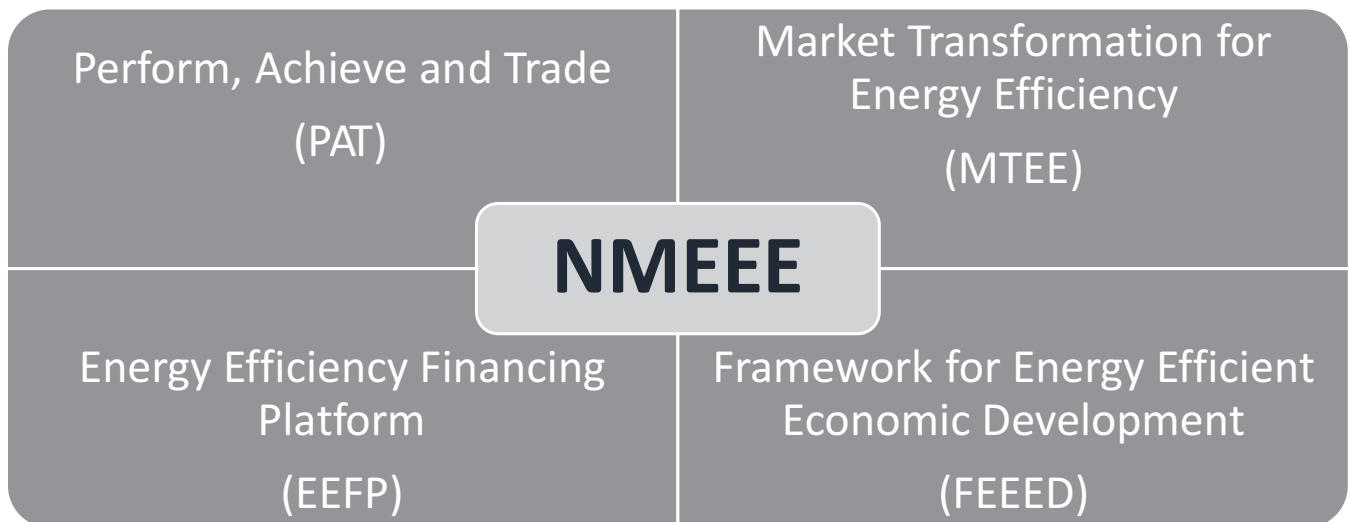



- **Market Transformation for Energy Efficiency (MTEE)** accelerates the shift to energy-efficient appliances in designated sectors through innovative measures that make the products more affordable.
- **Energy Efficiency Financing Platform (EEFP)**, a mechanism to finance demand side management programmes in all sectors by capturing future energy savings.
- **Framework for Energy Efficiency Economic Development (FEEED)**, for developing fiscal instruments to promote energy efficiency.

## 2. Perform, Achieve and Trade (PAT) Scheme

Under the National Mission on Enhanced Energy Efficiency (NMEEE), a market based mechanism known as Perform, Achieve and Trade (PAT) has been developed and launched to improve energy efficiency in the large energy intensive industries. It is envisaged that 6.686 million tonnes of oil equivalent will be reduced by 2014-15, which is about 4% of energy consumed by these industries. Under the PAT scheme, targets have been specified for all energy intensive industries notified as designated consumers (DCs) under the Energy Conservation Act, including thermal power stations.

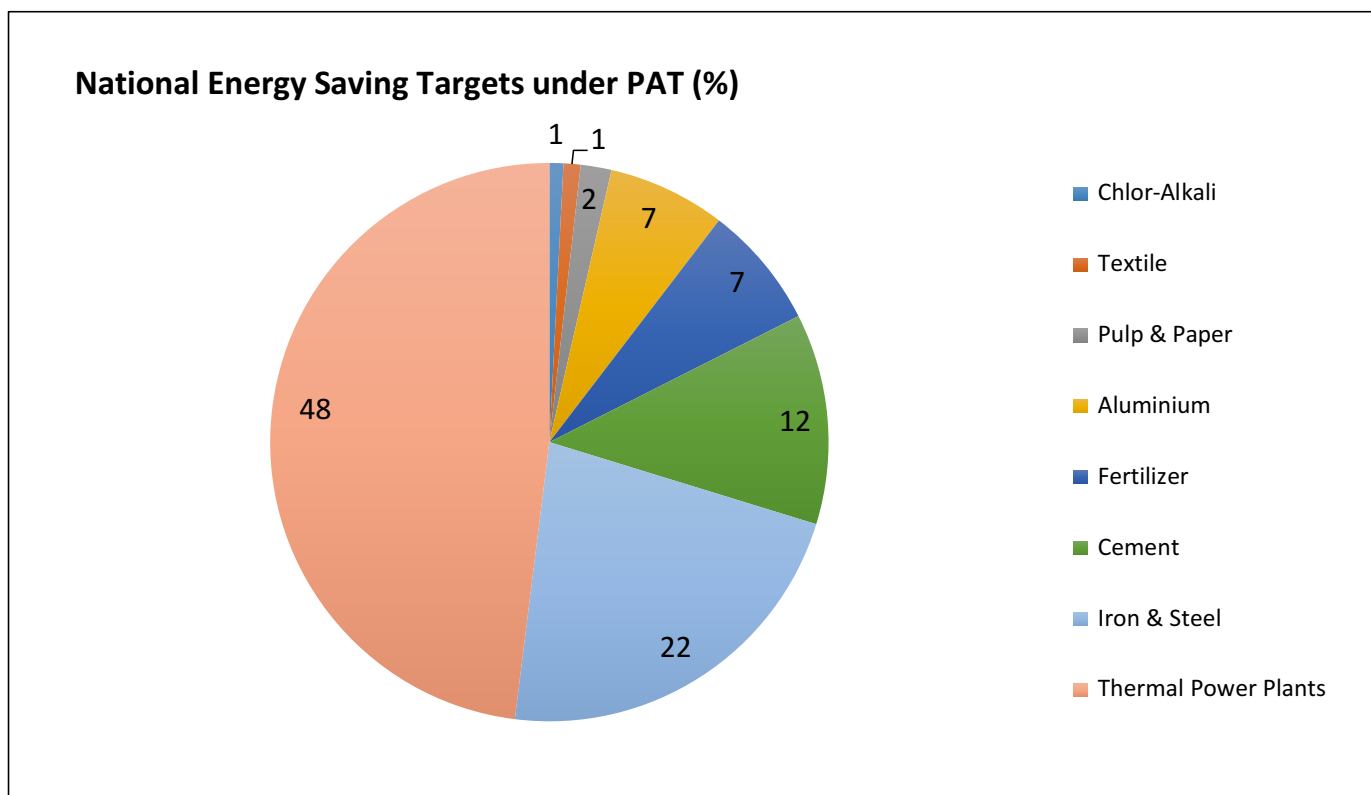

## 3. Background

The fertiliser industry in India has grown to its present size over five decades, starting in the 1960s. With a total production of about 38.6 million tonnes (mt) of fertiliser products containing 16.5 mt of plant nutrients (N + P<sub>2</sub>O<sub>5</sub>), India is the second largest producer of fertilisers

in the world. With a consumption of 28.12 mt of nitrogen (N), phosphate (P) and potash (K), India is the third largest consumer of fertilisers in the world. India's fertiliser industry is world class in terms of size of plants, technology used and efficiency levels achieved.

India produces both nitrogenous and phosphatic



fertilisers with installed capacity of 12.947mt nitrogen and 6.201 mt of P<sub>2</sub>O<sub>5</sub>. Urea is the major nitrogenous fertiliser and accounts for 83% of the total nitrogen production. Other nitrogenous fertilisers are ammonium sulphate (AS) and calcium ammonium nitrate (CAN), which are produced in smaller quantities. Among complex fertilisers, di-ammonium phosphate (DAP) and various grades of NP/NPK are produced. Apart from these, single super phosphate (SSP), also contributes to the phosphate production. There are about 141 fertiliser plants in operation in India. Out of these, 29 units produce urea, 19 units produce di-ammonium phosphate (DAP) and NP/NPK complex fertilisers, 82 units produce single super phosphate (SSP), 11 units produce ammonium sulphate, calcium ammonium nitrate and ammonium chloride.

India is completely dependent on import of potassic fertilisers mainly as potassium chloride. India produced about 22 mt urea in 2010-11. About 18 mt urea was produced using gas as feedstock, while balance about 4 mt was produced using naphtha and fuel oil as feedstock.

Among all the processes in the fertiliser industry, production of nitrogenous fertilisers is the most energy intensive. Ammonia is used as the basic chemical in the production of nitrogenous fertilisers. Globally, over 80% of all ammonia manufactured is used in the production of nitrogenous fertilisers, and urea is the main nitrogenous fertiliser manufactured in India. The feedstocks used for ammonia production are natural gas, naphtha and fuel oil. Coal based units have been closed due to non-economic viability and high specific energy consumption levels. Among the feedstock, natural gas-based fertilisers are the most energy efficient, followed by naphtha based fertilisers.

Most of the existing plants in operation, have upgraded the technology continuously by way of revamp, retrofit and replacements. Some of

the major upgradation are incorporation of radial-axial or radial flow ammonia converters, additional heat recovery from furnace flue gases, revamp of CO<sub>2</sub> removal section with better solvent, improved packing of absorption/desorption towers, additional purification of synthesis gas, use of more efficient catalyst, refurbishing or replacement of rotating machines including major compressors and turbines, better heat integration, utilisation of low level heat, etc. Four plants using fuel oil as feedstock are preparing to use gas as feedstock with total investment of the order of Rs 5,000 core.

There are 28 urea and one ammonia plants in operation in the country with capacity of 22.21 mt per annum. Most of these plants are of 1980s and 1990s vintage. With continuous efforts for upgradation of technology, these plants have brought down energy consumption from 8.42 Gcal/t in 1990-91 to 6.24 Gcal/t urea in 2010-11. The major modernisation measures include two-stage concentration, more efficient trays in urea reactor, recovery of nutrients from process effluents, recycling treated process condensate, refurbishing or replacement of rotating machines, etc. Most urea plants have energy consumption within a range of 5.25 to 6.0 Gcal/t urea. For manufacturing urea fertiliser, out of total energy consumed at designated consumer plant boundary, stoichiometric energy of 2.53 Gcal/t urea is contained in urea product and goes out as such.

Thus, the net energy utilised in urea manufacture is total energy input at designated consumers' boundary reduced by 2.53 Gcal/t Urea. The figure is worked out by considering heat energy of ammonia as 4.46 Gcal/t ammonia and specific consumption 0.567 t of ammonia/t urea. By the end of the first PAT cycle, the energy savings of 0.478 million tonne of oil equivalent/year is expected to be achieved, which is 7.15 % of total national energy saving targets assessed under PAT.

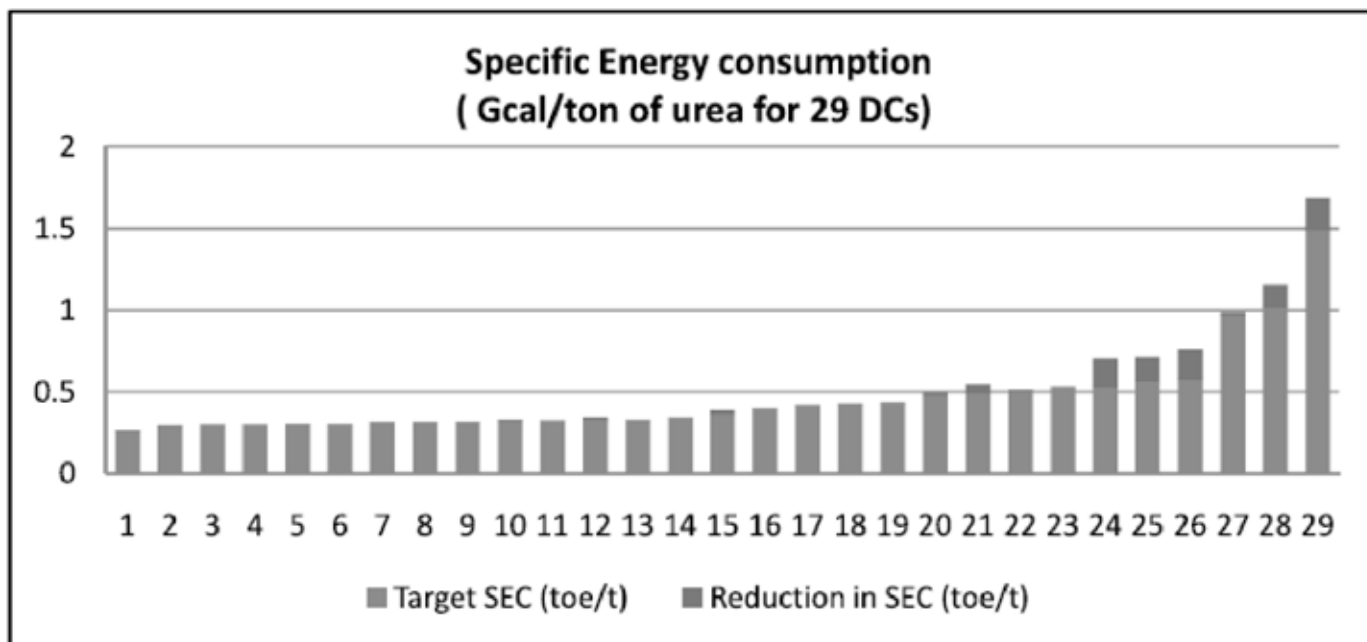

#### 4. Status of Designated Consumer (DCs)

Threshold limit for becoming a DC = 30000 metric tons of oil equivalent (MTOE) per annum  
Total number of identified DCs = 29.

Estimated Energy Consumption = (13.35- 5.15)  
= 8.20 Million Tonnes of Oil Equivalent.

#### 5.0 General Rules for Establishing Baseline Values

##### A. Definitions

[1] **Baseline Year**

Baseline year is declared as 2009-10.

[2] **Baseline Production ( $P_{base}$ )**

The arithmetic average of Production figures of 2007-08, 2008-09 and 2009-10

[3] **Baseline Specific Energy Consumption ( $SEC_{base}$ )**

The weighted average of SEC figures of 2007-08, 2008-09 and 2009-10.

[4] **Baseline Capacity Utilisation in % ( $CU_{base}$ )**

The arithmetic average of CU figures of 2007-08, 2008-09 and 2009-10.

##### B. Data Consideration

1. In case of plants more than 5 years old, data for the last 3 financial years will be considered, provided the CU is uniform. Normalisation will be done in case of abnormality in CU in any of the three years.
2. In case of plants more than 5 years old, but has data for less than 3 years, the same will be considered, provided the CU is uniform. If the CU is abnormally low in any of the years, the same will not be considered.
3. In case of plants less than 5 years old and has data for less than 3 years, the available year's (or years') data will be considered, provided the CU is uniform. If the CU is abnormally low in any of the years, the same will not be considered.
4. In case of new plants, the data would be considered for the years where the CU is greater than 70%. If data exists for only one year data, the same will be considered irrespective of the CU.





### C. Grouping of DCs

DCs are suitably grouped based on similar characteristics with the available data. This is to arrive at a logical and acceptable spread of SECs among DCs which may be compared in setting targets.

On analysis of the data, it has been observed, there is vast diversity in design and operating conditions of each plant. Some of these are enumerated below:

- Vintage of plants varies widely i.e. from year 1967 to 1999 ( 43 to 12 yrs )
- Size of single stream also varies i.e. for Ammonia / Urea from 600 / 1000 MTPD to 1500/2620 MTPD.
- Different feedstock is used i.e. NG, Naphtha, Fuel Oil.
- Technology in fertiliser industry has evolved successively over the last 5 decades. It is not financially viable for old generation plants to switch over to new generation technology.
- Drawing power from the state grid, causes unpredictable plant shut-downs due to fluctuations in frequency and also non-availability of power. A majority of plants have isolated from the state grid by installing captive power plants (CPP). However, some plants have power from both CPPs and the grid.
- In old plants (there are 6 of them), coal is used for steam and power generation, whereas new plants use NG.

*Under this scenario, each individual operating plant ( DC), operates under its unique operating environment. This ultimately has direct impact on energy consumption as well as potential to reduce the same. This makes it difficult to adopt a generalist approach for fixing*

*the targets of reduction in energy consumption.*

#### 5.1 Grouping of DCs for Fixing SEC Reduction Targets

A graph has been plotted showing weighted specific energy consumption after reducing energy contained in urea product i.e. 2.53 million Gcal/mt urea for three years, i.e. 2007-08, 2008-09, 2009-10, of each DC.

The SEC varies from 2.68 to 16.89 Gcal/mt urea. The average value is 4.0. The wide variation is due to a number of factors as brought out at section 3 above.

##### (1) Group - 1 ( DC's : 2)

BVFCL Namrup - II ( 1976) and BVFCL Namrup - III ( 1987) are having very high energy consumption of 16.89 & 11.54 Gcal/MT Urea respectively. These are operating at lower capacity utilization of around 70 % due to inherent problems arising out of location as well as technology. These Plants being out liars, have been segregated for fixing the targets. Assessed potential for reduction is 12 % for each Plant.

##### (2) Group - 2 ( DC's : 4)

In case of Fuel Oil based Plants ( 4 nos), energy consumption is very high i.e. 5.45 to 7.58 Gcal/MT Urea. These Plants came up between 1977 and 1982. All of these Plants are under conversion for switching over of feed stock to NG. This will reduce SEC, significantly. So, these Plants are treated as a separate group. Assessed potential for reduction is based on respective DFR.

- (a) In this Group, GNFC Bharuch ( 1982) is having lower energy consumption of 5.45 Gcal/MT Urea. Reduction in energy consumption targets is to be fixed based on revamped Plant using

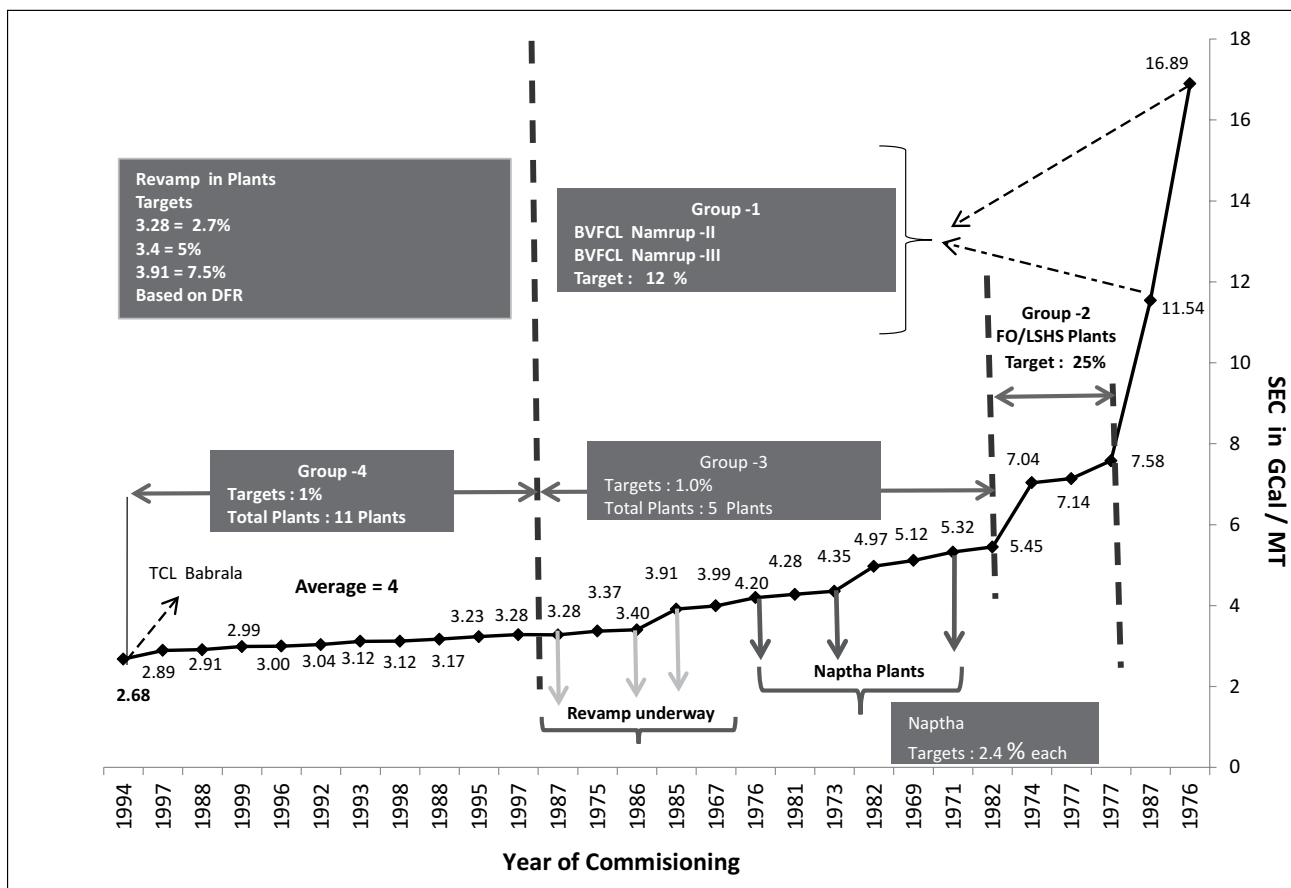

NG in place of Fuel Oil. Existing Plant shall also be utilized at part load to augment CO<sub>2</sub>. Commissioning is scheduled in 2012-13. Assessed potential for reduction is 10%.

- (b) NFL Nangal ( 1974), NFL Bhatinda (1977), NFL Panipat ( 1977) having energy consumption of 7.04, 7.14, 7.58 Gcal/MT Urea respectively are in the process of conversion for switching over feed stock to NG. Commissioning is scheduled in the year 2012-13. Reduction in energy consumption has been assessed as 25, 24, 22 % respectively.

**(3) Group - 3 ( DC's : 11)**

- (a) Old vintage Plants SCF Kota ( 1969), GSFC Vadodra ( 1967) & IFFCO Phulpur - I ( 1981) are having energy consumption of 5.1, 4.0, 4.28 G cal/MT Urea. These Plants were

originally designed for Naphtha feed. Subsequently, these have changed over to NG and also carried out retrofits. Thus, there is no margin left for further improvement. Assessed potential for reduction is 1.0 each.

IFFCO Kalol( 1975) is having lower SEC of 3.367 G cal/MT Urea. . Plant has carried out major retrofits during last 3 years. Assessed potential for reduction is 1 %.

RCF Trombay-V ( 1982) having energy consumption of 4.97 Gcal/ MT Urea has been under shut down and restarted only in the year 2009-10. Performance data for last 3 years is not available. Assessed potential for reduction is 2.0 %.

- (b) Three Plants have undertaken major retrofits, which are under implementation. Results will be



available during 2012-13. Their potential for reduction in SEC, has been assessed based on available information.

- (i) NFL Vijaipur - I (1987), having energy consumption of 3.28Gcal/MT Urea. Plant was commissioned in 1987. Assessed potential for reduction is 2.7 %.
- (ii) RCF Thal( 1985) is having energy consumption of 3.91 Gcal/MT Urea. Assessed potential for reduction is 6.5%.
- (iii) KRIBHCO Hazira( 1986) having energy consumption of 3.4 Gcal/MT Urea. Assessed potential for reduction is 5.0%.
- (c) Three Naphtha based Plants i.e. MFCL Mangalore ( 1976), ZIL Goa ( 1973), MFL Manali ( 1971) are having energy consumption of 4.2, 4.35, 5.32 Gcal/MT Urea respectively. *These Plants are still operating on Naphtha* due to non availability of NG. Use of Naphtha results in higher energy consumption. Assessed potential for reduction is 2.4 % each.

#### (4) Group - 4 ( DC's : 11)

Eleven Plants, were commissioned during nineties and late eighties. During this period, the technological development in manufacturing of ammonia / urea was at its peak. Plants having yearly capacity of 8,64,500 MT and using NG, came up during this period, are having low SEC. Also , these Plants have carried out further retrofits during last 3-4 years and the results in terms of reduction in SEC, have reflected in the Base line data. Thus, there is very little margin left for improvement without incurring huge expenditure, which may not be economically viable. Thus, a token value of 1.0% reduction in

SEC over average of last 3 years has been assessed. These Plants are :-

- a) TCL Babrala (1994) adopted innovative design and achieved exceptionally lower average energy consumption of 2.68 G cal / MT Urea, which is the lowest among Indian Plants. At the same time, it is at par with International standards.
- b) IFFCO Aonla II ( 1996) & CFCL Gadepan-I (1993) having average energy consumption of 3.0, 3.11 G cal/MT Urea.
- c) CFCL Gadepan- II ( 1999), IFFCO Phulpur - II ( 1997) have changed over from Naphtha to NG. These Plants are having average energy consumption 2.98, 3.28 Gcal/MT Urea respectively.
- d) NFCL Kakinada-II ( 1998) and NFCL Kakinada-I ( 1992), are having lower yearly capacity of 5,97,300 MT Urea each. Still these Plants are having low energy consumption of 3.03, 3.12 Gcal/MT Urea.
- e) NFL Vijaipur - II ( 1997) is NG based having energy consumption of 2.98 G cal/MT Urea. Plant was commissioned in 1997.
- f) KRIBHCO ShyamFert. Ltd. ( 1995) are having low energy consumption of 3.23 Gcal/MT Urea.
- g) IFFCO Aonla - I ( 1988) is having energy consumption of 3.167 G cal/MTUrea.
- h) IGFCL Jagdishpur (1988) is having low energy consumption of 2.94 Gcal/MT Urea.



(5) **FACT Udyogmandal** produce and also import ammonia. They do not produce Urea. During the last 3 years, average of Fatamphos Fertilizer produced is 127720 MT and that of Ammonium Sulphate Fertilizer is 112956 MT. This accounts for total energy consumption of 64263 MTOE,

and thus they qualify as DC. Their reported SEC is 9.84 G cal/MT Ammonia. It was decided that the targets for reduction shall be fixed based on SEC for Ammonia.

Assessed reduction target is 1.5% based on SEC, G cal/MT Ammonia

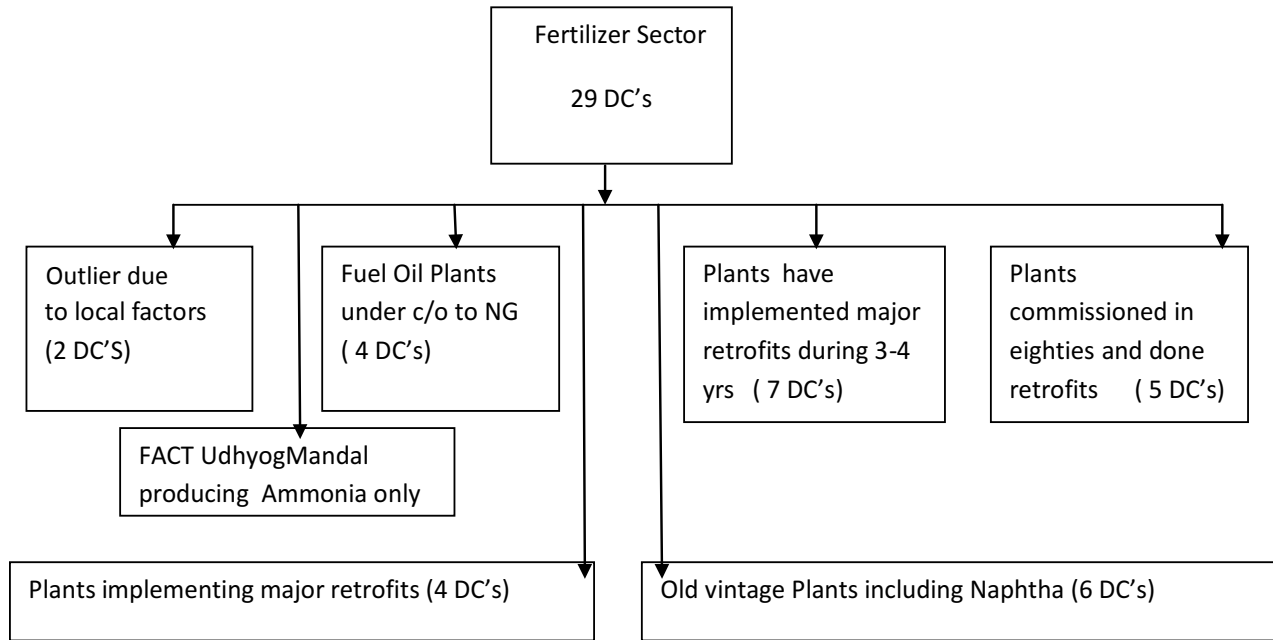

Block diagram showing total energy input at Plant BL as well as credit / debit of energy at intermediate stages for establishment of " Base Line SEC"  
To be filled-in by Designated Consumers ( DC's)

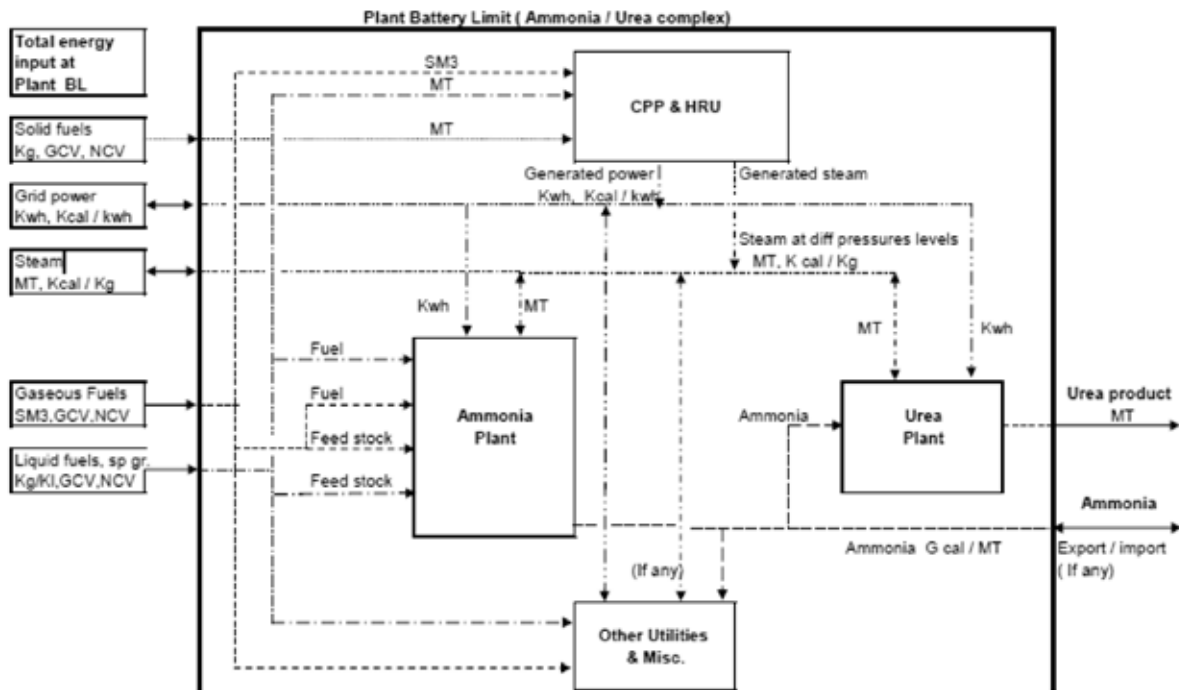



[A] The following exclusions are considered:

- (a) Energy consumed in internal transportation

[B] The equivalent thermal energy of the electricity supplied to the grid is DEDUCTED from the total energy input to the plant boundary. The following expression is used :

$$\text{Equiv. Thermal Energy (kCal)} = \text{Electricity supplied to Grid (kWh)} \times 2717 \text{ kCal/kWh}$$

[C] Correction factors which may be developed for variability during Target period

- (a) Higher energy consumption due to environmental regulations
- (b) Energy consumption due to temporary construction works, capacity expansion etc.

### E. Target Setting

- [1] Sectoral target is allocated based on a pro-rata basis of total energy consumption in the Fertilizer sector among all the 8 sectors under PAT scheme.
- [2] Sub-Sectoral target is allocated based on a pro-rata basis of total energy consumption in the sub-sector among the total aluminium sector.
- [3] The DC level target is allocated based on each DC's potential to reduce energy consumption., due to vast diversity in design and operating conditions of each DC. The DC level target is allocated based on a statistical analysis derived from 'Relative SEC' concept. This approach will be applicable to all the DCs of a sub-sector only.

### Apportionment of Sub-Sector Target of Energy Saving in Fertilizer Sector

Calculation of Energy Saving:

$$\text{Energy Saving} = P_{\text{base year}} (\text{SEC}_{\text{base year}} - \text{SEC}_{\text{target year}})$$

Where Energy Saving is in MTOE

$P_{\text{base year}}$  = Production in MT

SEC = Specific energy consumption in MTOE/MT

## 6.0 Normalization factors for the Fertilizer sector

### 6.1. Low capacity utilization

Lower capacity utilization due to following reasons has been considered for normalization (i) Shortage of raw material including feed, fuel, water, electricity etc. (ii) High cost of inputs leading to unviable urea production beyond certain capacity (iii) Major equipment failure (iv) Force majeure i.e. factors like shortage of raw materials (mainly the gas), decline in market demand, change in Govt. policy etc. which are beyond the control of Designated Consumers. These factors may force the plant to be operated at lower capacity, thus causing adverse effect on energy consumption. In such cases, normalization shall be allowed as follows:

#### 6.1.1. Pre-requisites for Normalisation

1. Designated Consumers shall furnish detailed and convincing reasons with supporting documents for reduction in capacity utilization, due to factors, beyond their control.
2. Following criteria shall be adopted:-
  - a) No compensation shall be allowed if the capacity utilization of urea plant on annual basis is 95% or above.
  - b) Compensation shall be allowed for capacity utilization between 70-95%.
  - c) Below 70%, the data shall be discarded.



3. The claim will be based on Technical operating data (TOP), which is being reported to Fertilizer Industry Coordination Committee (FICC) of Department of Fertilizers, Govt. of India.
4. Normalization due to low capacity utilization will be considered only in one of the plants i.e. either ammonia or urea.
5. Subsequent to the baseline year i.e.2007-10, some DCs have carried out major revamp of their plant for capacity enhancement in line with New Investment Policy for urea notified by the Govt. in 2008. Govt. recognized enhanced capacity, while reimbursing cost of production under the pricing policy. The enhanced capacity shall be considered, while calculating capacity utilization for normalization, subject to confirmation from DoF, Government of India and also verification certificate issued by an Accredited Energy Auditor to Designated Consumer which seeks to declare their enhanced installed capacities, production and energy use. Cost of this audit will be borne by the Designated Consumer. Check tests of such verification could be carried at by BEE, if needed.
6. Some plants are having ammonia plant capacity higher than the quantity of ammonia required for urea production and thus, diverting surplus ammonia for production of other products or direct sales. In such cases, due to Govt. policy and/or market conditions, consumption of surplus ammonia for production of other products becomes unviable and under these circumstances, ammonia plant is operated at lower capacity, thus resulting in higher energy consumption per MT of ammonia, which also get transferred to urea, even if the urea plant is operated at full load; Normalization shall be allowed.
7. In case of ammonia / urea complex having ammonia capacity matching with urea Production, capacity utilization of urea plant shall be considered.

#### 6.1.2. Calculation of normalization factor

1. Based on the operating data collected from plants at 100%, 85% and 70% plant load, average normalization factor works out to be 0.02 Gcal per MT of urea per percentage reduction in plant load below 95% up to 70%.
2. Impact of Lower Capacity utilization shall be worked out as follows:-
  - a. Maximum permissible value (Gcal/ MT urea) = (95 - % Capacity utilization) \* 0.02.
  - b. Actual unproductive energy (Gcal/ MT urea) = Annual Energy, Gcal/MT of Urea - Weighted Average of Monthly Energy Consumptions, GCal/MT urea for the months with Capacity Utilization of 100% or more
  - c. Lowest of the either (a) or (b) shall be considered for allowing the impact of lower capacity utilization.



### 6.1.3. Supporting data / documentation

Data shall be maintained in the following formats:-

1.3.1 Ammonia / urea production and energy data ( With Illustration)									
Sr. No.	Description	Unit	2007-08	2008-09	2009-10	Baseline data	Previous Year 2013-14	2014-15	Reference
A	B	C	D	E	F	G	H	I	
<b>1.0</b>	<b>Ammonia Plant</b>								
1.1	Installed capacity								
1.1.1	Re-assed capacity	MT	445500	445500	445500				TOP
1.1.2	Re-vamp capacity	MT						544500	TOP
1.1.3	Actual production	MT	302940	382165	506010	397038		507000	TOP
1.1.4	On stream days	days	301	324	365			362	TOP
1.1.5	Capacity utilization	%	68.0	85.8	113.6			93.1	TOP
1.1.6	Sp. Energy consumption	GCal/MT ammonia	7.634	7.520	7.098	7.370		7.253	TOP
<b>2.0</b>	<b>Urea Plant</b>								
2.1	Installed capacity								
2.1.1	Re-assed capacity	MT	370600	370600	370600				TOP
2.1.2	Re-vamp capacity	MT						396000	TOP
2.1.3	Actual production	MT	252000	333500	374300	319933		330000	TOP
2.1.4	On stream days	days	358	362	365			340	TOP
2.1.5	Capacity utilization	%	68.0	90.0	101.0			83.3	TOP
2.1.6	Sp. Energy consumption	Gcal/MT urea	6.395	6.604	6.542	6.525		6.500	TOP

TOP: Technical Operating Data as submitted to FICC. Data in the above table is representational and may vary from unit to unit.



1.3.2 Month-Wise production & energy consumption during the year ( 2014-15)											Reference : TOP	
			Daily capacity MTPD	Ammonia	1650				Urea	1200		
Sr. No.	Month	Ammonia					Urea					
		Monthly capacity	On stream	production	CU	SEC	Monthly capacity	On stream	production	CU	SEC	
		MT	days	MT	%	GCal/MT	MT	days	MT	%	GCal/MT	
1	April	49500	8	12000	24.2	8.560	36000	7	7500	20.8333	7.950	
2	May											
3	June											
4	July											
5	August											
6	September											
7	October											
8	November	49500	30	50490	102.0	6.955	36000	30	36900	102.5	6.452	
9	December											
10	January	51150	31	51670	101.0	6.905	37200	31	37760	101.5		
11	February											
12	March											

1.3.3 Monthly best performance during the year ( 2014-15)												
Sr. No.	Month	Ammonia					Urea					
		On stream	production	CU	SEC	Total energy	On stream	production	CU	SEC	Total energy	
		days	MT	%	Gcal/MT	Gcal/yr	days	MT	%	Gcal/MT	Gcal/yr	
1	November	30	50490	102	6.955	351158	30	36900	102.5	6.395	235975.5	
2						0					0	
3						0					0	
4						0					0	
5						0					0	
6						0					0	
	Sub-total		50490			351158		36900			235975.5	
	Weighted Average				6.955					6.395		
	Notes:											
	(i)	Take the month in which, plants have run for all the calendar days.										
	(ii)	Capacity utilization during the month should be equal to or above 100%.										





(iii) Similarly, tabulate data for the years 2007-08, 08-09, 09-10 and 2013-14

#### 6.1.4. Calculation of Normalization factor for low capacity utilization

Sr. No.	Description	Unit	Baseline data				Previous year	Assessment year 2014-15	Guidelines for filling data Reference to excel sheet
			2007-08	2008-09	2009-10	Average			
A	B	C	D	E	F	G	H	I	J
1	Urea plant capacity utilization	%	68.0	90.0	101.0			83.3	Based on "Re-assessed capacity" or "Revamp capacity: whichever is latest.
2	Eligibility for normalization	"True" is eligible	FALSE	TRUE	FALSE			TRUE	95>CU, CU>70 [Formula in excel sheet AND(95>V7,V7>70)]
3	Maximum permissible value	Gcal/MT urea		0.100				0.233	(95 - % Capacity utilization) * 0.02
4	SEC achieved	Gcal/MT urea	6.395	6.604	6.542	6.525		6.5	Actual from TOP ( Ref: Table 1.3.1 above);
5	Average SEC for best operating months	Gcal/MT urea	6.35	6.52	6.457			6.395	Ref : Table 1.3.2 above
6	Un-productive energy due to low CU( 4-5)	Gcal/MT urea	0.045	0.084	0.085			0.105	SEC achieved for year - Avg SEC for best operating months
7	Allowable un-productive energy; lower of Sr no 3 & 6	Gcal/MT urea	0.045	0.084	0.085	0.000		0.105	Lower of " Max permissible value" and " Un-productive energy due to low CU" [Formula in excel sheet MIN(V9,V12)]
8	Average impact on SEC during baseline period ( Weighted Average)	Gcal/MT urea				0.084			To be calculated manually for the baseline years in which Sr. No 2 is "True".
	Normalization Factor ( NF) due to low CU	Gcal/MT urea						0.021	Sr No I7 - Sr No G8

Units are advised to refer the Proforma (Production\_energy\_best monthly ) to Sd Form -1 for better understanding of the notations above. Data is purely representational and shall vary from DC to DC .

## 6.2. Cold startup of the plant after forced shut down

In case of sudden failure of a critical equipment, or external factors (as notified), ammonia plant undergoes a forced shut down. Restarting the plant from cold conditions (Cold start up), consumes unproductive energy and shall be normalized. Cold start up is defined as Fuel and Feed cut to reformer for a minimum period of 72hrs.

### 6.2.1. Pre-requisites for Normalization

1. The list of critical equipment failure of which leads to complete shutdown of plant and consequent cold start up, allowed under this normalization factor is given below :-
  1. Primary Reformer
  2. Secondary Reformer
  3. Heat Exchange Reformer



4. Reformed Gas Boiler
  5. Carbon dioxide absorber and stripper
  6. Air, Refrigeration and synthesis compressors
  7. Synthesis converters
  8. Synthesis Gas Waste Heat Boilers
  9. High pressure urea reactor, stripper and carbamate condenser
  10. Carbon dioxide compressor
  11. Utility boiler furnace
  12. Gas turbine/HRSG
  13. Cooling Tower
  14. Major Fire leading to complete shutdown of plant and cold startup
  15. Turbo generator along with GTG
  16. Purifier
  17. CO Shift Converter
2. The Designated Consumer (Designated Consumer) shall furnish a detailed report on failure of such equipment and its impact on energy consumption. The Designated Consumer shall declare with back up documentation, what portion of such unproductive consumption during the month is due to cold shutdown and startup activity.
3. This actual energy loss due to shut down and cold startup in Gcal/MT of Urea shall be compensated, subject to maximum of 0.03 Gcal/MT of Urea.

#### **6.2.2. Calculation of normalization factor**

1. Energy loss during the month(s) for which additional cold startup is being claimed shall be calculated as follows:-
  - a. (Monthly Energy per MT of Ammonia during the month - Weighted Average Monthly Energy Consumption per MT of Ammonia for the months with 100% on-stream days) X Monthly Ammonia production for the month of Startup.

- b. This Energy Loss shall be divided by Annual Urea Production to identify total unproductive loss in a month.
- c. The Designated Consumer shall declare what portion of such unproductive consumption during the month is due to cold shutdown and startup activity.
- d. This actual energy loss due to shut down and cold startup in Gcal/MT of Urea shall be compensated, subject to maximum of 0.03 Gcal/MT of Urea.

#### **6.3. Use of naphtha**

1. Using part naphtha involves additional energy consumption as follows:-
  - a) For each startup of facilities to use naphtha as feed including pre-reformer
  - b) For the period of use of naphtha as feed
  - c) For the period of use of naphtha as fuel
2. Designated Consumers shall furnish detailed and convincing reasons with supporting documents for use of naphtha due to non-availability of gas on account of factors, beyond their control.

##### **6.3.1. Pre-requisites for Normalization**

1. As per directives from Department of Fertilizers, Govt. of India, use of naphtha is to be discontinued in phased manner. As such, use of naphtha is not foreseen. However, provision is being made, in case naphtha has to be used due to shortage of natural gas in future, with permission from DoF.
2. In case of use of naphtha, Designated Consumer will furnish details regarding Non-availability of gas, leading to use of naphtha.



### 6.3.2. Calculation of normalization factor

Following formula shall be used Energy loss (Gcal /MT Urea) =  $(185 \cdot S + 0.625 \cdot N_{\text{feed}} + 0.443 \cdot N_{\text{fuel}})$  / urea production in MT

S= 1 if naphtha is used as feed in startup

S= 0 if naphtha is not used as feed in startup

$N_{\text{Feed}}$  = quantity of naphtha used as feed in MT.

$N_{\text{Fuel}}$  = quantity of naphtha/LSHS/FO used as fuel in MT.

### 6.4. Catalyst reduction

Fresh catalyst is in oxidized form and needs to be reduced with synthesis gas, wherein hydrogen reacts with oxygen and gets converted into water. Whole plant is operated at 60-80% load for around 48 to 120 hours, depending upon type and quantity of catalyst.

Thus, replacement / reduction of ammonia synthesis and CO shift catalysts consumes large amount of unproductive energy. Therefore, normalization due to replacement / reduction of these catalysts will be allowed.

#### 6.4.1. Pre-requisites for Normalization

1. In case of ammonia synthesis catalyst, in the older plants, oxidized form of the catalyst is used which takes around 4-5 days for reduction, causing corresponding un-productive energy consumption. Presently, "Pre-reduced catalyst" is also available, which is expensive but takes around 48 hours for reduction, thus consuming lesser un-productive energy. This aspect will be taken care, while calculating normalization factor.
2. This will be considered subject to certification by DCs and furnishing to BEE information as follows:
  - a) Year in which the catalyst were last changed along with copies of

purchase order, last placed with the vendor , time taken in commissioning of catalyst , facts and figures clearly indicating and quantifying rise in the energy consumption of plant due to the replacement of this catalyst.

- b) Copies of purchase orders placed by units with the vendors for supply of fresh catalysts.

### 6.4.2. Calculation of normalization factor

Adjustment shall be allowed on the basis of actual plant data, subject to a maximum of 0.04 Gcal/MT of Urea.

### 6.5. Deterioration in quality of Coal

The quality of indigenous coal has been deteriorating gradually, thus affecting boiler efficiency adversely. The reduction in boiler efficiency due to poor quality of coal shall be compensated.

#### 6.5.1. Pre-Requisites for Normalization

Weighted average of three years data shall be worked out. In case there is significant variation, then normalization factor shall be applied based on the actual impact due to the variation.

#### 6.5.2. Calculation of normalization factor

1. Quality of coal affects boiler efficiency, which shall be calculated by following empirical formula:-

$$\text{BoilerEfficiency} = 92.5 - ((50 \cdot A + 630(M + 9H)) / \text{GCV})$$

Where

A = Ash content of coal (%)

M = Moisture (%)

H = Hydrogen (%)

GCV = Kcal/Kg



2. Boiler efficiency shall be converted into specific energy consumption, as follows:

Additional Energy Consumption, Gcal/MT of Urea = Energy of Coal per MT of Urea in Target Year, Gcal/MT of Urea\* (Boiler Efficiency in Base Year - Boiler Efficiency in Target Year)/Boiler Efficiency in Target Year.

#### 6.6. Additional provisions

1. Normalization factors to be applied during assessment year, shall also be applied on baseline data for 2007-10.
2. Provision of normalization factors is intended solely to save plants from penalties for non-achieving the saving

targets, for reasons which are beyond the control of DCs. However, availing of any of the normalization factors shall render the DC ineligible for issuance of E-certificates under PAT scheme. Therefore, DCs may seek normalization factors only when the specified energy saving target is not achieved for reasons beyond the control of DC.

3. Designated Consumers claim will be examined based on Technical operating data (TOP), which is being reported to Fertilizer Industry Coordination Committee (FICC) of Department of Fertilizers, Govt. of India as well as by Accredited energy auditors designated by Bureau of Energy Efficiency (BEE).

## **Part-II**

# **MONITORING & VERIFICATION GUIDELINES**





# 1. Introduction

## 1.1. Background

Ministry of Power and Bureau of Energy Efficiency (BEE) have been implementing several programs for efficient use of energy and its conservation. This is further supplemented by the National Mission for Enhanced Energy Efficiency (NMEEE), which is one of the missions under the National Action Plan on Climate Change (NAPCC), launched by Hon'ble Prime Minister on 30th June 2008 to ensure increase in the living standards of the vast majority of people while addressing climate change concerns.

The Perform Achieve and Trade (PAT) Scheme is one of the initiatives under the NMEEE program, which was notified on 30th March 2012. PAT scheme is a market assisted compliance mechanism to accelerate implementation of cost effective improvements in energy efficiency in large energy-intensive industries, through certification of energy savings that could be traded. The genesis of the PAT mechanism flows out of the provision of the Energy Conservation Act, 2001 (Amended in 2010).

The key goal of the PAT scheme is to mandate specific energy efficiency improvements for the most energy intensive industries. The scheme builds on the large variation in energy intensities of different units in almost each notified sector, ranging from amongst the best in the world and some of the most inefficient units. The scheme envisages improvements in the energy intensity of each unit covered under it. The energy intensity reduction target, mandated for each unit is dependent on its current efficiency: the reduction target is lesser for those who are more efficient, and is higher for less-efficient units.

Ministry of Power, in consultation with Bureau of Energy Efficiency has prescribed the energy consumption norms and standards, in exercise of the power conferred under clause (g) and

(n) of section 14 of the Energy conservation Act 2001 (Amended in 2010) for the Designated Consumers vide S.O. 687 (E) [Energy Conservation (Energy Consumption Norms and Standards for Designated Consumers, Form, Time within which, and Manner of Preparation and Implementation of Scheme, Procedure for Issue of Energy Savings Certificates and Value of per Metric Ton of Oil Equivalent of Energy Consumed) Rules, 2012] dated 30/03/2012 (Containing Baseline Specific Energy Consumption, Product Output and Target Specific Energy consumption for the Designated Consumers). The said S.O. Notification is based on the Rules notified under G.S.R. 269 (E) [Energy Conservation (Energy Consumption Norms and Standards for Designated Consumers, Form, Time within which, and Manner of Preparation and Implementation of Scheme, Procedure for Issue of Energy Savings Certificates and Value of per Metric Ton of Oil Equivalent of Energy Consumed) Rules, 2012] dated 30th March, 2012, herein referred as PAT Rules, 2012

The scheme covers 478 Units, known as Designated Consumer (DC) in 8 sectors (Thermal Power Stations, Iron and Steel Plants, Cement, Fertiliser, Textile, Pulp and Paper, Chlor Alkali & Aluminium sector) in the cycle I. Together these designated consumers used about 36% of the fossil fuel consumed in India in 2010. Each designated consumer has been mandated to achieve a specific reduction in its specific energy consumption. Percentage reduction targets were notified in March, 2012, and the percentage reduction target is less for a designated consumer that is already efficient, and more for one that is less efficient. Overall, all the plants together are to achieve a 4.05% reduction in the average energy consumption by the year 2014-15. This would imply a reduction of about 6.686 million tons-of-oil-equivalent in their annual energy consumption, and a reduction of about 23 million tons of carbon dioxide annually.



A robust monitoring, reporting and verification process will ensure effective and credible assessment of energy performance, achieved by industries covered under PAT.

## 1.2. Purpose

A reliable monitoring, reporting and verification (M&V) system forms the backbone of assessment process of the PAT scheme. The objective of the M&V system is to streamline the activities to be carried out for verifying the energy performance achieved by the Designated Consumer in the target year.

The documents sets out the requisite guidelines for M&V in the Monitoring and Verification phase under the PAT Rules. It provides practical guidance and procedure to Designated Consumers (DCs) and Empanelled Accredited Energy Auditors (EmAEA) on verification requirements, and aims to establish a verification process consistent with relevant rules and regulation.

The Assessment of performance verification involves an independent evaluation of each activity undertaken by the DCs for compliance under PAT rules. Verification plays a crucial role in maintaining the integrity of the scheme and ensuring transparent validation.

The verification process will ensure that the information and data in Form 1 and Proforma are free from material omissions, misrepresentations and errors.

The process requires EmAEA to verify the monitoring and verification of energy performance of DCs in accordance with PAT rules while taking into the consideration, Normalization factors and any other relevant conditions as defined PAT Rules

The verification must be completed between 1st April to 30th June of the year, following the assessment year. Submission of final verification

report, verified annual Form 1, Sector Specific Proforma, EmAEA's verification report along with authentic supporting documents shall be done by the DC to the concern State Designated Agency (SDA) and Bureau of Energy Efficiency before 30th June.

### The document:

- Provides Designated Consumers and EmAEA set of guidelines to establish methods for assessment of specific energy consumption.
- Defines broad techniques for assessing/determining factors that effects the performance of establishment.
- Provides general terms, which are applicable to all sectors and also includes specific sector term.
- Will be guided as per the provisions conferred under Rule 3 of PAT Rules 2012.
- Provides support to the Designated Consumer to meet its obligation specified in Rule 7 and Rule 15 of the PAT Rules.

## 1.3. Definition of M&V

M&V is the process to verify the Specific Energy Consumption through verifiable means of each Designated Consumer in the baseline year and in the assessment year by an empanelled accredited energy auditor.

The underlying principles for Monitoring and Verification include:

- ▶ **Consistency:** By applying uniform criteria to meet the requirements of the sector specific methodology throughout the assessment period.
- ▶ **Transparency:** Information in the verification reports shall be presented in an open, clear, factual, neutral and coherent manner based on documentary evidence
- ▶ **Acceptability:** The Empanelled Accredited Energy Auditors shall base their findings and conclusions upon objective evidence,





conduct all activities in connection with the validation and verification processes in accordance with the rules and procedures laid down by BEE, and state their validation or verification activities, findings, and conclusions in their reports truthfully and accurately.

- ▶ **Measurability:** Measurement is a fundamental starting point for any kind of data captured for Energy Performance Index.
  - i. Measurement in energy saving projects: The energy saving from any project is determined by comparing measured parameters before and after implementation of a project, making appropriate adjustments for changes in conditions.
  - ii. Measurement of parameters for data captured in Pro-forma: The parameters entered in the pro-forma shall be taken from the measured logs with supporting documentation through
  - iii. Computational documentation from basic measurement at field
  - iv. Measurement activities in the baseline and assessment year consist of the following:
    - meter installation, calibration and maintenance
    - data gathering and screening,
    - development of a computation method and acceptable estimates from the basic measurement at field,
    - computations with measured data, and
    - reporting, quality assurance

A measurement boundary is a notional border drawn around equipment and/or systems that are relevant for determining the savings achieved through implementation of Energy saving projects.

- ▶ **Traceability:** The documents presented for substantiating the reduction in specific energy consumption or savings from ECM should be verifiable and visible.
- ▶ **Verifiability:** The validation of filled in data in the Pro-forma and savings from Energy Conservation Measures through proper authentic documentation are to be carried out by the EmAEA.

#### 1.4. Empanelled Accredited Energy Auditor or Verifier

Accredited Energy Auditor firm empanelled with BEE under PAT rules will be the verifier of PAT M&V process

“verification” means a thorough and independent evaluation by the accredited energy auditor of the activities undertaken by the designated consumer for compliance with the energy consumption norms and standards in the target year compared to the energy consumption norms and standards in the baseline year and consequent entitlement or requirement of energy savings certificate.

“certification” means the process of certifying the verification report or check-verification report by the accredited energy auditor to the effect that the entitlement or requirement of energy savings certificate is quantified accurately in relation to compliance of energy consumption norms and standards by the designated consumer during the target year;

“check-verification” means an independent review and ex-post determination by the Bureau through the accredited energy auditor, of the energy consumption norms and standards achieved in any year of the three year cycle which have resulted from activities undertaken by the designated consumer with regard to compliance of the energy consumption norms and standards;



### 1.4.1. Qualification of Empanelled Accredited Energy Auditor (EmAEA) for Verification and Check-Verification

A firm registered under the Indian Partnership Act, 1932 (9 of 1932) or a company incorporated under the Companies Act, 1956 (1 of 1956) or any other legal entity competent to sue or to be sued or enter into contracts shall be entitled to undertake verification and check-verification regarding compliance with the energy consumption norms and standards and issue or purchase of energy savings certificate if it,-

- (a) has at least one accredited energy auditor whose name is included in the list of the accredited energy auditors maintained by the Bureau under regulation 7 of the Bureau of Energy Efficiency (Qualifications for Accredited Energy Auditors and Maintenance of their List) Regulations, 2010;
- (b) has at least three energy auditors;
- (c) has adequate expertise of field studies including observations, probing skills, collection and generation of data, depth of technical knowledge and analytical abilities for undertaking verification and check-verification;
- (d) has a minimum turnover of ten lakhs rupees per annum in at least one of the previous three years or in case of a newly formed organisation, a net worth of ten lakhs rupees.

The application shall be accompanied by a certificate of registration or incorporation as the case may be.

### 1.4.2. Obligation of Empanelled Accredited Energy Auditor

For the work of verification or check verification, the accredited energy auditor shall constitute a team comprising of a team head and other members including Process Experts:

Provided that a person who was in the employment of a designated consumer within the previous four years, shall not be eligible to perform the work of verification or check-verification for such designated consumer;

- (1) Provided further that any person or firm or company or other legal entity, who was involved in undertaking energy audit in any of the designated consumer within the previous four years, shall not be eligible to perform the work of verification or check-verification for such designated consumer.
- (2) The accredited energy auditor shall ensure that persons selected as team head and team members must be independent, impartial and free of potential conflict of interest in relation to activities likely to be assigned to them for verification or check-verification.
- (3) The accredited energy auditor shall have formal contractual conditions to ensure that each team member of verification and check-verification teams and technical experts act in an impartial and independent manner and free of potential conflict of interest.
- (4) The accredited energy auditor shall ensure that the team head, team members and experts prior to accepting the assignment inform him about any known, existing, former or envisaged link to the activities likely to be undertaken by them regarding verification and check verification.
- (5) The accredited energy auditor must have documented system for determining the technical or financial competence needed to carry out the functions of verification and check -verification and in determining the capability of the persons, the accredited energy auditor shall consider and record among other things the following aspects, namely:-
  - (a) complexity of the activities likely to be undertaken;



- (b) risks associated with each project activity;
  - (c) technological and regulatory aspects;
  - (d) size and location of the designated consumer;
  - (e) type and amount of field work necessary for the verification or check-verification.
- (6) The accredited energy auditor shall have documented system for preparing the plan for verification or check-verification functions and the said plan shall contain all the tasks required to be carried out in each type of activity, in terms of man days in respect of designated consumers for the purpose of verification and check - verification.
  - (7) The names of the verification or check-verification team members and their bio-data shall be provided by the accredited energy auditor to the concerned designated consumer in advance.
  - (8) The verification or check-verification team shall be provided by the accredited energy auditor with the concerned working documents indicating their full responsibilities with intimation to the concerned designated consumer.
  - (9) The accredited energy auditor shall have documented procedure-
    - (i) to integrate all aspects of verification or check-verification functions;
    - (ii) for dealing with the situations in which an activity undertaken for the purpose of compliance with the energy consumption norms and standards or issue of energy savings certificate shall not be acceptable as an activity for the said purposes.
  - (10) The accredited energy auditor shall conduct independent review of the opinion of verification or check-verification team

- and shall form an independent opinion and give necessary directions to the said team if required.
- (11) In preparing the verification and check-verification reports, the accredited energy auditor shall ensure transparency, independence and safeguard against conflict of interest.
  - (12) The accredited energy auditor shall ensure the confidentiality of all information and data obtained or created during the verification or check verification report.
  - (13) In assessing the compliance with the energy consumption norms and standards and issue of energy savings certificates, the accredited energy auditor shall follow the provisions of the Act, rules and regulations made thereunder.
  - (14) After completion of the verification or check-verification, the accredited energy auditor shall submit the verification (in Form- "B") or check-verification report, together with the certificate in Form-'C', to the Bureau.

### 1.5. Important Documents required for M&V process

- I. Accepted Baseline Audit Report (Available with BEE and DC)<sup>1</sup>

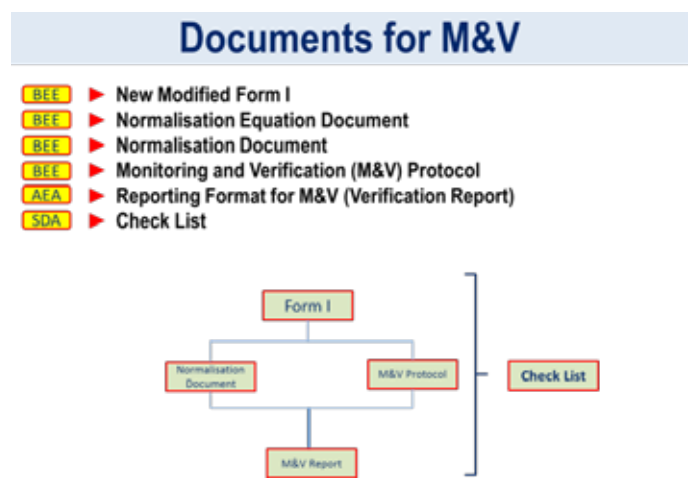

Figure 1: M&V Documents

<sup>1</sup>Baseline Report: Available with BEE and respective DCs. EmAEA to verify the consistency of Report



- II. Form 1 & Sector Specific Pro-forma available with BEE
- III. Form A,B,C,D as covered in PAT rules
- IV. Normalisation Factors Document available with BEE
- V. Normalisation Guidelines Document
- VI. Check List to be used by all stakeholders
- VII. Reporting Format for EmAEA
- VIII. ESCerts Management Registry

**Figure 2: Stakeholders**

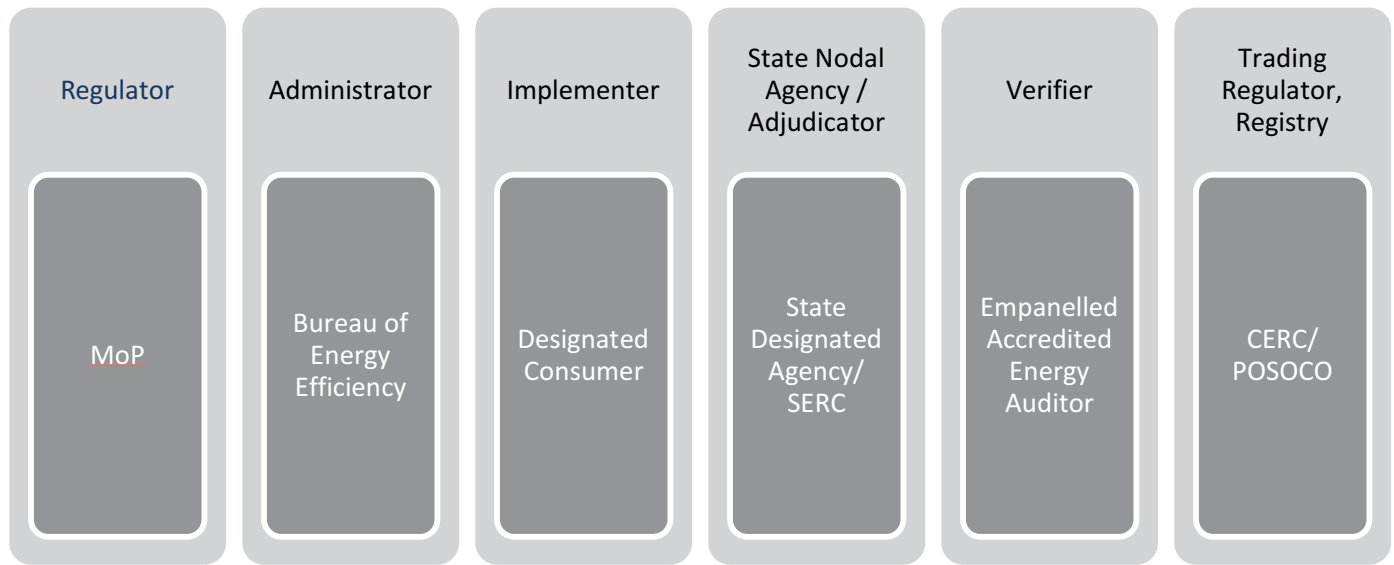

## 2. Broad Roles and Responsibilities

The various roles assessed to be performed in the verification process include administration, regulation and services delivery. The key stakeholders are Ministry of Power, Bureau of Energy Efficiency, State Designated Agencies, Adjudicator, Designated Consumers and Empanelled Accredited Energy Auditor.

### 2.1. General

The roles and responsibilities of individuals and designated consumer are set out in Energy Conservation Rules 2012<sup>2</sup>

The roles and responsibilities of the Designated Consumer (DC), Empanelled Accredited Energy Auditor (EmAEA), Bureau of Energy Efficiency (BEE), State Designated Agencies (SDA),

Adjudicator and Ministry of Power (MoP) can be summed up as under

The Designated Consumer shall fill the data in the Sector Specific Pro-forma and Form 1 stating source of data in the Form, of its installation as per GtG boundary concept manually in Excel Sheet Pro-forma and in PATNET. The filled in Forms with the authentic source of data in terms of hard copy document shall have to be kept ready by Designated Consumer for verification. The designated consumer in consultation with the EmAEA, shall put in place transparent, independent and credible monitoring and verification arrangement. The verifier shall ensure transparency, independence and safeguard against conflict of interest.

As part of verification process, the EmAEA shall

<sup>2</sup>Energy Conservation Rules 2012: Energy Consumption Norms and Standards for Designated Consumers, Form, Time within which, and Manner of Preparation and Implementation of Scheme, Procedure for Issue of Energy Savings Certificate and Value of Per Metric Ton of Oil Equivalent of Energy Consumed) as per Notification G.S.R.269 (E) dated 30th march 2012



carry out a strategic and statistical Analysis, checking of relevant and authentic document, Quarterly, Yearly and End of Cycle internal data audit reports, Performance Assessment Documents (Form A), Form I and sector specific pro-forma from DCs, the actual verification produce an internal verification report, Form B from EmAEA. These verified Forms, documents and reports will then be submitted to the SDA with a copy to the Bureau. The SDA, in turn after proper verification of Form A sent by DC may send comment to BEE for final verification based on the SDA Check List.

If the accredited energy auditor records a positive opinion in his verification report, the Bureau shall consider that all the requirements with regard to the compliance with energy consumption norms and standards, entitlement about issue or liability to purchase energy savings certificate have been met.

BEE on satisfying itself about the correctness of verification report, and check-verification report, wherever sought by it, send its recommendation under clause (aa) of sub-section (2) of section 13 to the Central Government, based on the claim raised by the designated consumer in Form 'A', within ten working days from the last date of submission of said Form 'A' by the concerned state designated agency, for issuance of energy savings certificates under section 14A. Guidance on these responsibilities are presented in the Energy Conservation Rules 2012.

## 2.2. Designated Consumer

The Designated Consumers have the following responsibilities with respect to EOC or mid cycle verification as per guidelines in Energy Conservation Rules 2012:

1. To monitor and report in accordance with the monitoring plan approved by the BEE.
2. Establish data and information management system as per Sector

Specific Supporting Pro-forma for Form 1, Normalization formulae

3. M&V arrangements for energy consumption and production by Designated Consumer
4. Without prejudice to the monitoring plan approved by the BEE, DC must comply with on-going obligations imposed under PAT Rules 2012
5. The monitoring methodology or the Input Data Entry with Normalisation factors shall be changed if this improves the accuracy of the reported data and for taking out any errors reported by DC in the Sector Specific Pro-forma (Linking formulae, error formulae or wrong data entry)
6. The designated consumer in consultation with the accredited energy auditor, shall put in place transparent, independent and credible monitoring and verification arrangements for energy consumption and production based on the Bureau of Energy Efficiency (Manner and Intervals of Time for Conduct of Energy Audit) Regulations, 2010 for compliance with the energy consumption norms and standard, and the said arrangements shall include,-
  - i) Preparation and Maintenance of Quarterly Data Reports to be prepared by DCs from 2012 onwards up to assessment year
    - a. On the performance of plant and production process
    - b. Internal Field Audit Report on Energy and Process
  - ii) Preparation and Maintenance of Yearly Data Reports to be prepared by DCs from 2012 onwards up to assessment year
    - a. On the performance of plant and production process



- b. Outcome of Internal Field Audit
  - c. Measures to reduce energy consumption and improve energy efficiency
  - d. Measures taken to improve the efficiency of the production processes during each year
- iii) Preparation and Maintenance of Yearly Data Reports to be prepared by DCs from 2012 onwards up to assessment year
- a. Report on production achieved, energy consumed
  - b. specific energy consumption achieved, specific energy consumption
  - c. reduction achieved, measures adopted for energy conservation and quantity of energy saved;
- iv) Preparation and Maintenance of Consolidated End of Cycle (EOC) Data Reports to be prepared by DCs from 2012 onwards up to assessment year
- a. Report on production achieved, energy consumed
  - b. specific energy consumption achieved, specific energy consumption
  - c. reduction achieved, measures adopted for energy conservation and quantity of energy saved;
7. The DC has to maintain in set tabulated format and set reports template as per above guidelines for submission to EmAEA
8. The DC has to fill the data in the Sector Specific Pro-forma for the Normalisation factors including M&V protocol for its facility in conformity with the Sectoral Normalisation factor guidelines prepared by BEE
9. The data to be filled in the latest version of MS Office Excel sheet and PATNET
10. Designated Consumers shall facilitate verification and check-verification work by the EmAEA and SDA.
11. The designated consumers shall,-
- (a) for assessment of their performance for compliance with the energy consumption norms and standards, get the work of verification done through accredited energy auditors;
  - (b) take all measures including implementation of energy efficiency projects recommended by the accredited energy auditor and good practices prevalent or in use in the concerned industrial sector so as to achieve the optimum use of energy in their plant :
- I furnish the full and complete data, provide necessary documents and other facilities required by the accredited energy auditor for the purpose of performing the function of verification and check-verification.
12. The designated consumer for the purpose of achieving the compliance with the energy consumption norms and standards during the target year, in the relevant cycle shall take the following action and after completing the said action, furnish the status of compliance to the concerned state designated agency with a copy to the Bureau in Form 'D' by the end of five months from the last date of submission of Form 'A'-
- (a) by implementation of energy conservation and energy efficiency improvement measures or;
  - (b) where the measures implemented in terms of clause (a) are found



inadequate for achieving compliance with the energy consumption norms and standards, the designated consumer shall purchase the energy savings certificates equivalent in full satisfaction of the shortfall in the energy consumption norms and standards worked out in terms of metric ton of oil equivalent.

### 2.3. Empanelled Accredited Energy Auditor (EmAEA)

The EmAEA is responsible for verification of Energy Consumption Norms and Standards for Designated Consumers, Gate to Gate Specific Energy Consumption of baseline and assessment year as per guidelines of PAT Rules 2012 with subsequent attributes:

13. To ensure that the verification is carried out by properly trained and competent staff as per Section 1.4.2
14. The EmAEA is responsible for ensuring that the systems and processes adopted by the DC for determination of GtG SEC from the data in Sector Specific Proforma along with Normalisation sheets and information protocol have been maintained in conformity with the various notifications and information provided by BEE/SDA from time to time
15. EmAEA is required to perform different roles such as technical review of manufacturing processes & energy consumption patterns, system variabilities and their impact on energy consumption, and on issues including application of statistical methods and finally performance of verifications including integrity of data
16. The accredited energy auditor shall independently evaluate each activity undertaken by the designated consumer for compliance with the energy consumption norms and standards and entitlement or

requirement of energy savings certificate, to ensure that they meet with the requirements of these rules.

- (A) The accredited energy auditor, in order to assess the correctness of the information provided by the designated consumer regarding the compliance with energy consumption norms and standards shall-
  - (a) Apply standard auditing techniques;
  - (b) Follow the rules and regulation framed under the Act;
  - (c) Integrate all aspects of verification, and certification functions;
  - (d) Make independent technical review of the opinion and decision of the verification team; also take into consideration, a situation where a particular activity may or may not form part of the activities related to the compliance with the energy consumption norms and standards, and the procedure for the assessment shall include,-
- (B) Document review, involving
  - (i) Review of data and its source, and information to verify the correctness, credibility and interpretation of presented information;
  - (ii) Cross checks between information provided in the audit report and, if comparable information is available from sources other than those used in the audit report, the information from those other sources and independent background investigation;
- (C) Follow up action, involving-
  - (iii) Site visits, interviews with personnel responsible in the designated consumers' plant;



- (iv) Cross-check of information provided by interviewed personnel to ensure that no relevant information has been omitted or, over or under valued;
- (v) Review of the application of formulae and calculations, and reporting of the findings in the verification report.

(D) The accredited energy auditor shall report the results of his assessment in a verification report and the said report shall contain,

- (a) The summary of the verification process, results of assessment and his opinion along with the supporting documents;
- (b) The details of verification activities carried out in order to arrive at the conclusion and opinion, including the details captured during the verification process and conclusion relating to compliance with energy consumption norms and standards, increase or decrease in specific energy consumption with reference to the specific energy consumption in the baseline year;
- (c) the record of interaction, if any, between the accredited energy auditor and the designated consumer as well as any change made in his assessment because of the clarifications, if any, given by the designated consumer.

- 17. EmAEA to prepare a verification report as per Reporting template to be provided by BEE
- 18. EmAEA to resolve errors, omissions or misrepresentations in the data/records/calculations in consultation with the DCs prior to completing the verification report

19. EmAEA to resolve calculation errors in the Sector Specific Pro-forma consultation with the BEE prior to completing the verification

#### 2.4. State Designated Agencies (SDA)

All the documents like verified Sector Specific Pro-forma, Form 1, Verification report of EmAEA and related documents will be routed to BEE via SDA.

20. The technical role of SDA are

- i. Inspection & enforcement for M&V related systems
- ii. Assist BEE in information management process
- iii. Review and validation of Sector Specific Pro-forma, Form 1, Verification report of EmAEA and related documents before sending it to BEE
- iv. After submission of duly verified Form 'A' by designated consumer, SDA may convey its comments, if any, on Form 'A' to the Bureau within fifteen days of the last date of submission of Form 'A'.
- v. BEE, in consultation with SDA may decide to undertake review on Check verification
- vi. The EmAEA in-charge of check-verification shall submit the report with due certification Form C to the BEE and the concerned SDA
- vii. The State designated agency may furnish its comments on the report within ten days from the receipt of the report from the said EmAEA. In case no comments are received from the concerned state designed agency, it shall be presumed that they have no comments to offer in the matter





viii. The State designated agency within two months from the date of the receipt of the report referred to in sub-rule (9) shall initiate-

- (a) action to recover from the designated consumer the loss to the Central Government by way of unfair gain to the designated consumer;
- (b) penalty proceedings against the persons mentioned in the said report, under intimation to the Bureau;
- (c) register complaint for such fraudulent unfair gain if designated consumer does not pay penalty and loss to the exchequer in the specified time mentioned in the penalty proceedings.

21. The administrative role of SDA are

The designated agency may appoint, after the expiry of five years from the date of commencement of this Act, as many inspecting officers as may be necessary for the purpose of ensuring compliance with energy consumption standard specified under clause (a) of section 14 or ensure display of particulars on label on equipment or appliances specified under clause (b) of section 14 or for the purpose of performing such other functions as may be assigned to them.

Subject to any rules made under this Act, an inspecting officer shall have power to -

- (a) inspect any operation carried on or in connection with the equipment or appliance specified under clause (b) of section 14 or in respect of which energy standards under clause (a) of section 14 have been specified;
- (b) enter any place of designated consumer at which the energy is

used for any activity and may require any proprietor, employee, director, manager or secretary or any other person who may be attending in any manner to or helping in, carrying on any activity with the help of energy to afford him necessary facility to inspect-

- (A) any equipment or appliance as he may require and which may be available at such place;
- (B) any production process to ascertain the energy consumption norms and standards

## 2.5. Adjudicator

Section 17 and Section 28 of EC Act 2001 shall be referred for power to adjudicate

## 2.6. Bureau of Energy Efficiency

BEE shall co-ordinate with the Designated Consumers, SDA, Sectoral technical committee and other agencies to administer and monitor the Scheme as per PAT Rules and EC Act 2001.

- 22. BEE recommend to the Central Government the norms for processes and energy consumption standards required to be notified under clause (a) of section 14 of Energy Conservation Act 2001
- 23. Preparation and Finalization of Sector Specific Pro-forma for annual data entry in consultation with the Technical Committee set up by BEE
- 24. Preparation and finalization of Sector Specific Normalization Factors applicable in Assessment year in consultation with Technical Committee set up by BEE
- 25. Empanelment of Accredited Energy Auditor Firm as Verifier for M&V



26. Capacity building of SDA, EmAEA, Energy Manager of DCs
27. The Bureau on satisfying itself about the correctness of verification report, and check-verification report, wherever sought by it, send its recommendation under clause (aa) of sub-section (2) of section 13 to the Central Government, based on the claim raised by the designated consumer in Form `A', within ten working days from the last date of submission of said Form `A' by the concerned state designated agency, for issuance of energy savings certificates under section 14A

## 2.7. Ministry of Power

28. Roles and Responsibilities of Central Government have been covered under Energy Conservation Act 2001 and notified PAT Rules 2012

## 2.8. Institutional Framework for PAT

Transparency, flexibility and Industry engagement in program design help ensure effective industrial energy efficiency policy with adequate buy-in from the covered facilities. PAT's design phase involved extensive consultations with the DCs. Consultations ensured the design phase was transparent and allowed industry to engage in the process.

Since, PAT being largely a federal government scheme, hence involvement of State Designated Agencies as an extended arm of enforcement agency ushers outcome in the right direction.

An institutional frame work consisting of State Designated Agencies, Designated Consumers, Accredited Energy Auditors, Trading Exchanges<sup>3</sup> and Financing facilities has been established to implement the scheme. Bureau of Energy Efficiency is leading the process with state level capacity supported by AEA and Sectoral Technical committee constituted for rationalizing the process.

Figure 3: Institutional Framework

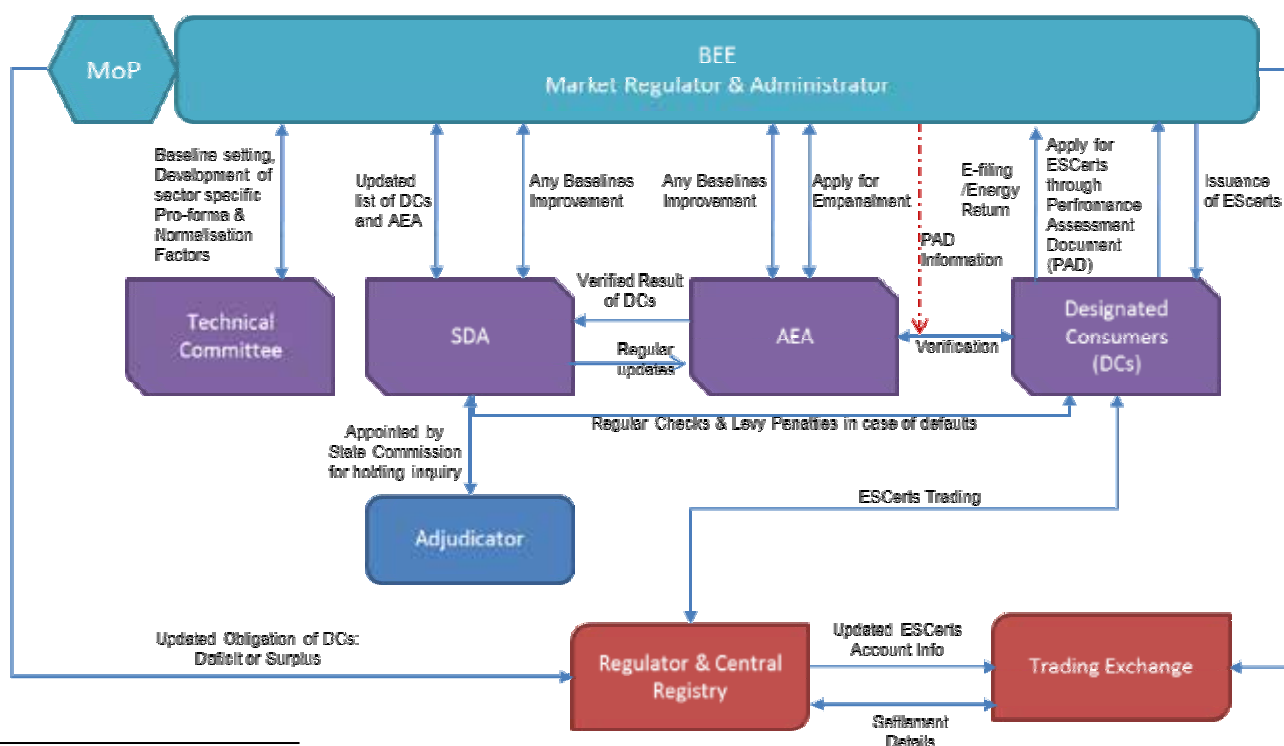

<sup>3</sup> Trading Exchanges: IEX & PXIL



### 3. Process & Timelines

#### 3.1. Activities and Responsibilities

The Energy Conservation Rules, 2012 clearly defines the timelines of activities and responsibilities to be carried out for accomplishment of PAT scheme. Timely submission of action plan from DC to trading of ESCerts needs to be done in a definite time zone. Constant performance monitoring of the

program by the Administrator, through parameters like total ESCerts issued & traded, complying sectors or participants, market liquidity etc., will be carried out. Delays at any point of the process-chain will be identified and timely action be taken by the Administrator/Regulator.

Automation of processes wherever feasible will be carried out for seamless implementation of the PAT scheme.

**Table 1: Activities and Responsibilities for PAT Cycle I**

S. No	Name of Form	Submitted by	Time of Submission	Submission authorities
1.	Form A	DCs	Three months from conclusion of target year (end of first, second or third year of relevant cycle) <b>30th June, 2015</b>	SDA & BEE
2.	Form B (Certificate of verification by AEE)	DCs	Three months from conclusion of target year (end of first, second or third year of relevant cycle) <b>30th June, 2015</b>	SDA & BEE
3.	BEE's Recommendation to MoP for issuance of ESCerts	BEE	10 working days from receipt of forms A & B	Ministry of Power
4.	Issuance of ESCerts	Central Government (MoP)	Within 15 days from receipt of recommendations by BEE	BEE
5.	Form D (status of Compliance)	DC	End of 5 months from the last date of submission of Form A	SDA & BEE
6.	Form C (check verification report and certificate)	AEA (Accredited Energy Auditor)	Within 6 months after issuance of ESCerts or within 1 year of submission of compliance report	BEE



### 3.2. Process Interlinking

targets to issuing Escerts are interlinked among different stakeholders complying a definite time frame as defined below

The complete process from notifying the

Figure 4: Stakeholders Interlinking

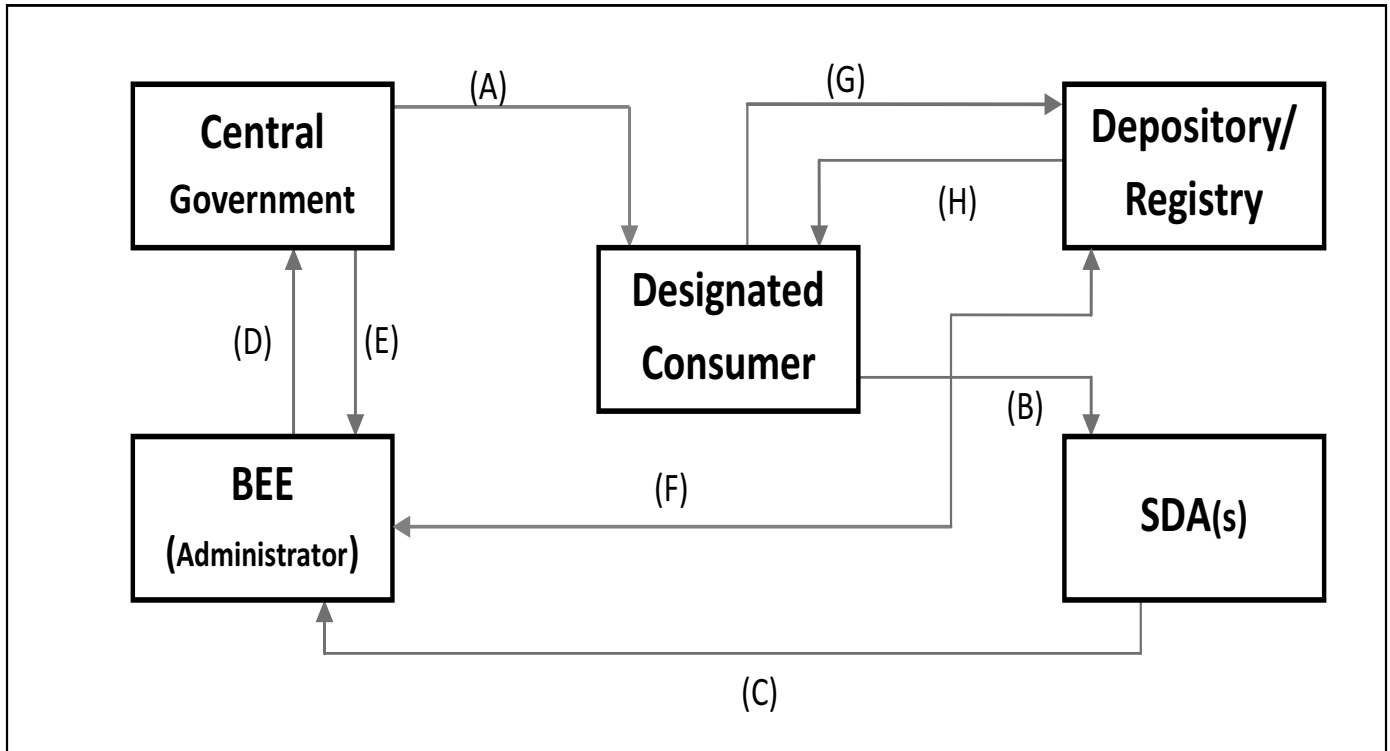

- (A) Targets from Central Government to DCs
- (B) Performance Assessment Document (Form A) from DC to SDA
- (C) PAD (Form-A) with recommendation for issuance, if overachieved from SDA to BEE
- (D) Recommendation of ESCerts Issuance by BEE to Central Government
- (E) ESCerts Issuance Instruction from Central Government to BEE
- (F) Electronic ESCerts Issuance Instruction from BEE to Depository
- (G) DC Interaction with Depository A/c
- (H) ESCerts credit to DC's A/c

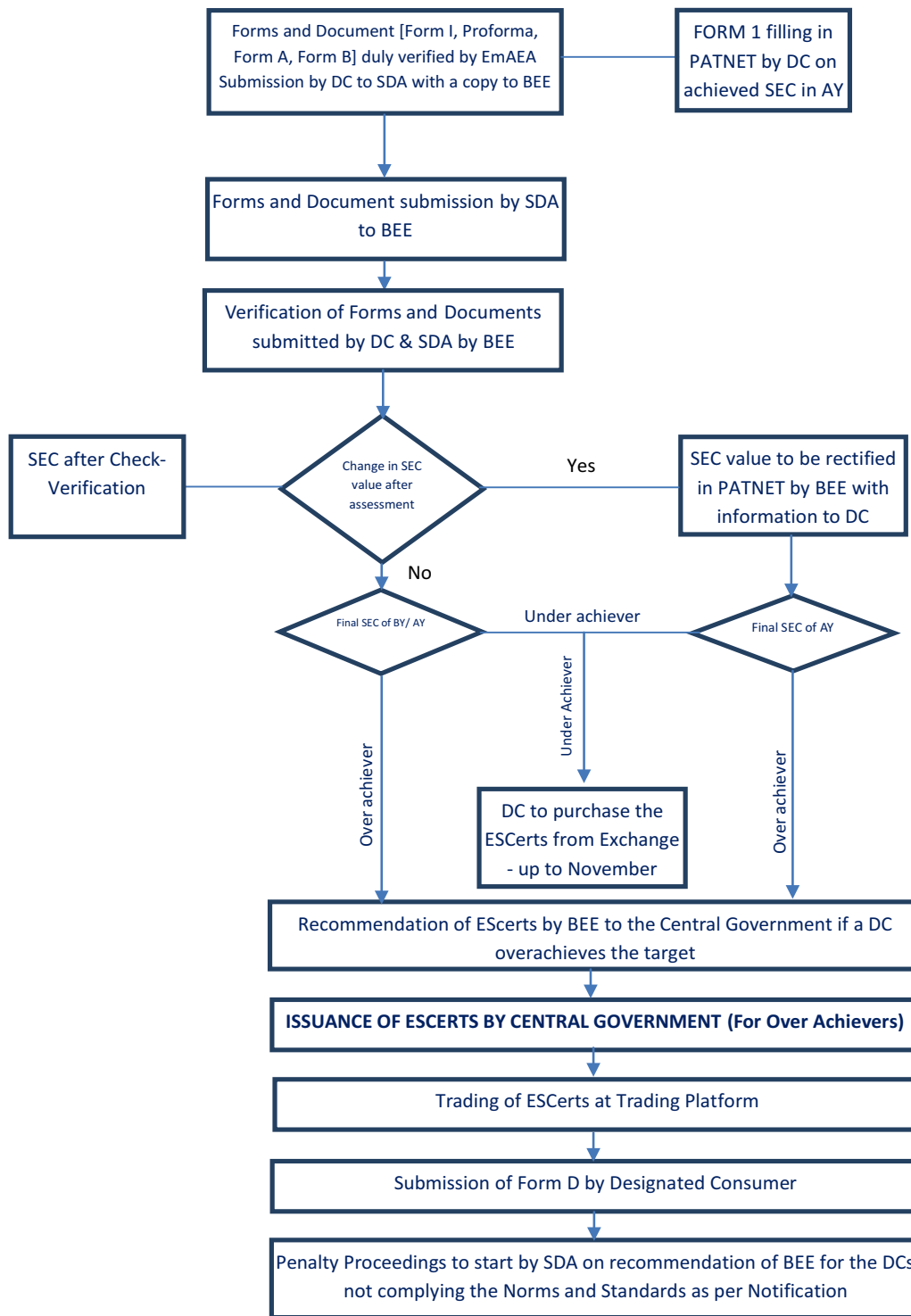

**Figure 5: Flow Chart of ESCerts issuance**

29. Penalty for Non-Achievement of Target

i. Compliance as per Form D of Energy Conservation Rules 2012

(a) Energy savings certificates: Enter +ve value if energy savings

certificates issued to designated consumer or enter -ve value in case recommended for purchase of energy savings certificates

(b) Energy savings certificates



submitted for compliance: If designated consumer is recommended for purchase of energy savings certificates, then enter value of energy savings certificates submitted by designated consumer for compliance of energy consumption norms and standards- saving target of designated consumer.

(c) Balance energy savings certificates:- Numbers of energy savings certificates balance. If balance is ZERO than DC is in accordance for compliance of

energy saving target and if balance is -ve than DC will be recommended for penalty.

- ii. For Penalty and Power to adjudicate, refer section 26 and 27 of the EC Act 2001
- iii. As per EC Act, 2001, section 26, Fixed penalty is maximum 10 Lakh and variable penalty is price of 1 TOE as specified in Energy Conservation Rules 2012. Any amount payable under this section, if not paid, will be recovered as if it were an arrear of land revenue.

3.3. Flow Chart showing verification process (Rules and Act required dates in ***bold Italics***)

Responsibility	Date	Action and Stages of verification process
DC	<b><i>By June 30 each Year</i></b>	Submission of Energy Return Form I and Sector Specific Supporting Pro-forma for Form 1
DC	<b><i>By June 30 [First Year of PAT Cycle]</i></b>	Submission of Action Plan
DC	<b><i>Before M&amp;V phase of PAT Cycle</i></b>	Hiring of Empanelled Accredited energy Auditor
DC/EmAEA	<b><i>April 1-June 30 [After completion of relevant PAT cycle]</i></b>	Monitoring and Verification
DC	<b><i>By June 30 [M&amp;V phase of PAT Cycle]</i></b>	Submission of Verified Form I and Sector Specific Pro-forma, Form A, Form B and Other Document to SDA & BEE
DC	<b><i>By June 30 [After end of 1<sup>st</sup> and 2<sup>nd</sup> Year PAT Cycle] For Advance ESCerts</i></b>	Submission of Verified Form I and Sector Specific Pro-forma, Form A, Form B and Other Document to SDA & BEE
SDA	<b><i>[15 days of the last date of sub. of Form A]</i></b>	Submission of Comments on Verified Form I and Sector Specific Pro-forma, Form A, Form B and Other Document to BEE
BEE	<b><i>[10 working days from last date of submission of Form A by SDA][M&amp;V phase of PAT Cycle]</i></b>	Recommendation of Energy Saving Certificates to Central Government <b><i>[10 working days from last date of submission of Form A by SDA]</i></b>
Central Government	<b><i>[15 working days from date of receipt of recommendation by BEE][M&amp;V phase of PAT Cycle]</i></b>	Issue of Energy Saving Certificates <b><i>[15 working days from date of receipt of recommendation by BEE]</i></b>
DC	<b><i>[5 months from date of submission of Form A by DC to SDA][M&amp;V phase of PAT Cycle]</i></b>	Submission of Form D to SDA and BEE <b><i>[5 months from date of submission of Form A by DC to SDA]</i></b>
BEE/Power Exchange	<b><i>[M&amp;V phase of PAT Cycle]</i></b>	ESCerts Trading period

Figure 6: Time Line Flow Chart



## 4. Verification requirement

### 4.1. Guidelines for Selection Criteria of EmAEA by Designated Consumer

30. The EmAEA will be selected only from the List of EmAEA as available in the BEE official website
31. The procedure for selection of EmAEA should be followed from guidelines of PAT Rules 2012
32. The Designated Consumer may select EmAEA based on their experience in Energy Auditing Field and in the related sector as per information in Form III and Form IV (REGISTER CONTAINING LIST OF ACCREDITED ENERGY AUDITORS) Submitted by the Accredited Energy Auditor ([www.bee-india.nic.in](http://www.bee-india.nic.in))
33. The EmAEA preferably have attended at least one Training Programs organized by Bureau of Energy Efficiency on Monitoring and Verification Guidelines.
34. The Designated Consumer needs to verify following during selection of AEA
  - (a) Provided that a person who was in the employment of a designated consumer within the previous four years, shall not be eligible to perform the work of verification or check-verification for such designated consumer;
  - (b) Provided further that any person or firm or company or other legal entity, who was involved in undertaking energy audit in any of the designated consumer within the previous four years, shall not be eligible to perform the work of verification or check

verification for such designated consumer.

35. EmAEA is required to submit the documentation on determining the capability of the team on Technical and financial competence after getting the formal order from Designated Consumer
36. EmAEA is required to submit the Name and detailed Bio-data on Energy Audit or Verification experiences of the team head, team members and experts to the DC prior to selection
37. The Designated Consumer to ensure that the EmAEA must have documented system on preparing plan for verification or check-verification along with activities chart defining task in man-days for the DC.
38. The selection process of EmAEA needs to be completed before 31st March of the end of PAT Cycle
39. The scope of work may cover the time period till the check verification.

### 4.2. Guidelines for Empanelled Accredited Energy Auditor

40. For the Work of verification, EmAEA shall constitute a team in accordance to section 10 of Energy Conservation Rules, 2012; comprising following team members
41. Where ever necessary, EmAEA must state any discrepancies in their final verification reports. Potential improvements to achieve more accurate reporting in line with the PAT Rules and EC Act.



**Table 2: Team Details (Minimum Team Composition)**

Sr No	Designation	Qualification	Experience
1	Team Head	Accredited Energy Auditor	In the Field of Energy Auditing of PAT Sectors <sup>4</sup>
2	Team Member [Expert]	Graduate Engineer	Process or Technical Expert related to the specific sector, where verification will take place having experience of more than 10 years
3	Team Member	Certified Energy Auditor	In the Field of Energy Auditing
4	Team Member	Graduate/ Diploma Engineer	

42. The EmAEA may constitute any nos of team for verification or check-verification purpose to carry out the verification process for nos of Designated Consumer.
43. The EmAEA shall ensure that it has formal contractual conditions of team members including technical experts for verification and check-verification so as to act in an impartial and independent manner and free of potential conflict of interest.
44. The EmAEA, has the sole responsibility and signing authority on Form B, Form C
45. The verification by EmAEA should be completed for onward submission to SDA and BEE before 30th June in the year following the assessment year.
46. The EmAEA should furnish a time plan and activities chart to DC after receiving valid order from the respective designated Consumer
47. The Designated Consumer shall inform Bureau of Energy Efficiency about the date of start of verification by EmAEA.
48. The verification shall not be carried out by two different EmAEA for the particular DC in a single PAT cycle.
49. The audit report shall be certified by the EmAEA and shall be counter signed by

- the DCs Energy Manager and Competent Authority
50. EmAEA to submit an undertaking along with Form B indicating that there is no conflict of interest in the team assigned and PAT Rules 2012 and its amendments have been complied.

#### **4.3. Guidelines for Verification process**

##### **4.3.1. Sector Specific Pro-forma**

The Sector Specific Pro-forma is made with the purpose of capturing the data for Production, Energy and Normalization factors under equivalent condition for the baseline and assessment year. The filled in Pro-forma is used to calculate the Notional Energy for Normalization. Once complete data is filled in the Pro-forma, the SEC after Normalization automatically comes out in the summary sheet enabling the DC to see the actual performance of the plant

51. The Energy Conservation (Form and Manner for submission of Report on the Status of Energy Consumption by the Designated Consumers) Rules, 2007 directs every designated consumers to submit the status of energy consumption in electronic form as well as hard copy, within three

<sup>4</sup> PAT Sectors: Thermal Power Stations, Steel, Cement, Aluminium, Fertiliser, Pulp & Paper, Textile, Chlor-Alkali





months, to the designated agency with a copy to Bureau of Energy Efficiency at the end of the previous financial year in Form-1.

52. The Sector Specific Pro-forma have many sections to cover all the aspects of GtG<sup>5</sup> methodology as follows:

- ▶ Instruction for Form 1 filling
- ▶ General Information Sheet
- ▶ Form 1
- ▶ Sector Specific Pro-forma
  - o Production and Capacity Utilization Details
  - o Section wise details of different products
  - o Electricity and Renewable Energy Consumption
  - o Power Generation (DG/GG/GT/STG/Co-Gen/WHR)
  - o Fuel Consumption (Solid/Liquid/Gas/Biomass & Others)
  - o Heat Rate of different power sources and Coal Quality
  - o Miscellaneous Data for Normalisation
- ▶ Additional Equipment installation due to Environmental Concern
- ▶ Project Activities details
- ▶ Summary Sheet
- ▶ Normalization calculation sheets

53. The Form 1 will be automatically generated after filling the Pro-forma, which is required to be filled in the PATNET as input for final assessment of GtG SEC for the baseline and assessment year.

54. Formulae cells in Pro-forma, Summary sheet and Normalisation calculation

sheets are locked to ensure data security, reliability etc.

55. There are five columns in the Sector Specific Pro-forma. Three columns are used for Baseline years i.e., Year 1, Year 2 and Year 3, the fourth column will be used for computing the average data of the baseline years and the fifth one for entering the data in Year 4 i.e. Assessment year/Target year/Current year.

56. The Sector Specific Pro-forma will be used for mandatory submission of annual Energy return. The data will be filled in the year 3 column as previous year and year 4 as current year after making the others column cells empty.

57. Average of the three baseline years is taken as baseline data for Normalisation

58. For the purpose of taking average of baseline year, other columns are not to be kept blank. However, if plant's data contains only one or two year operation, then the third year column should be kept as blank.

59. Cells have been Colour coded and locked for data security purpose in the Pro-forma.

#### 4.3.2. Reporting in Sector Specific Pro-forma

60. Baseline parameter and Plant boundary in Gate to Gate Concept means

##### ▶ Plant Boundary for Energy and Product

- Input Raw material
- Output product
- CPP installed within premises or outside the plant demographic boundary
- Energy inputs and Outputs (Electricity/Gas/Steam etc)

<sup>5</sup> GtG: Gate to Gate



► **Defining Input Energy in Sector Specific Pro-forma**

- Fuel Input to the Captive Power Plants
- Fuel Input to the Process
- Bifurcation of Input Energy for Renewables/Alternate source/Biomass etc in Captive Power Plants
- Not connected with Grid-The energy used from the Renewables/Alternate source/Biomass will not be added in the total input energy
- Connected with Grid-The energy used from the Renewables/Alternate source/Biomass will be added in the total input energy
- Waste Heat Recovery
- Co-generation
- Accounting of Energy generation and Energy used inside the plant boundary

► **Raw material input and Product output**

- Intermediary semi-finished Product output for market sale- the energy for making the intermediary product to be deducted from the total energy consumption
- Intermediary semi-finished Product input as raw material in between the process- the energy for making up to the semi-finished intermediate product to be added in the total energy consumption.

61. The baseline Production and Energy related data to be entered in Sector Specific Pro-forma as per Baseline Report by individual DCs. The same will be verified by EmAEA.
62. The DCs are required to fill the data as per instruction sheets in all the relevant

baseline and assessment year data field with source of data

63. The entered baseline data in the Excel Sheets will be locked for data security by BEE. The DC can enter data in all the fields other than locked Cells.
64. The Locked-in Sector Specific Pro-forma is to be sent to DCs for data entry.
65. The primary and secondary source of data should be kept ready in hard copies for verification by EmAEA as per guidelines in the instruction sheet.
66. The DCs are advised to fill the data in Excel Sheets only and return the same in Excel form to SDAs with a copy to BEE along with hard copies of Form 1, Sector Specific Pro-forma, Summary and all Normalisation sheets duly signed.

**4.3.3. Verification Process**

As part of the verification process, the EmAEA shall carry out the following steps:

67. The EmAEA after receiving the work order is advised to get the final Baseline report (Accepted by BEE) from the DC.
68. The EmAEA shall conduct a site visit on mutually agreed dates with Designated Consumer, to inspect the monitoring systems, conduct interviews, and collect sufficient information and supporting documentary evidence vide Sector Specific Pro-forma.
69. Prior to visiting the site, the EmAEA is advised to study the Baseline reports, Sector Specific Pro-forma and Sector specific Normalisation document
70. For computing SEC in Gate-to-Gate concept, the plant boundary was established such that the total energy input and the defined product output is fully captured. Typically, it is the entire plant



excluding colony, residential complex and transportation system. Similarly, mining operations in the case of Iron & Steel, Aluminium and Cement sector do not fall under plant boundary.

The same boundary should be considered for entire PAT cycle as finalised for the baseline year in the final Baseline Energy Audit Report. Ideally, plant boundary should not change during the entire cycle. Any change in plant boundary limit or merger of two plants, division of operation should be duly reported. The definition of Plant boundary should be considered same as established in the baseline year

- 71. The EmAEA will assign the activities among team members for verifying the data through the Pro-forma, Documented Primary and secondary sources, Field reports, conducting interviews, site visits etc.
- 72. The filled in Baseline data for Production and Energy shall be verified through Baseline Report by EmAEA.
- 73. The additional Baseline data filled by DC needs to be verified based on authentic

documentary evidence.

- 74. The baseline verified data shall be considered as final data to be filled in the sector specific pro-forma. In case of any typographical or factual error, the same shall be taken into account after taking into account corrected during verification process subject to all factual and authentic data source is available by DC. The EmAEA may take into account while preparing the verification form B.
- 75. The SEC calculation methodology as devised in the pro-forma shall be considered.
- 76. In case of any discrepancies observed in baseline data w.r.t. the Baseline reported data, the same should be reported to BEE with proper justification from EmAEA or DC for rectification in the existing Sector Specific Pro-forma. The rectified Pro-forma from BEE will be sent to the DC through e-mail.
- 77. Officials from Bureau of Energy Efficiency may visit Designated Consumers' Plant during the course of verification by EmAEA.

Figure 7: Stakeholders Output

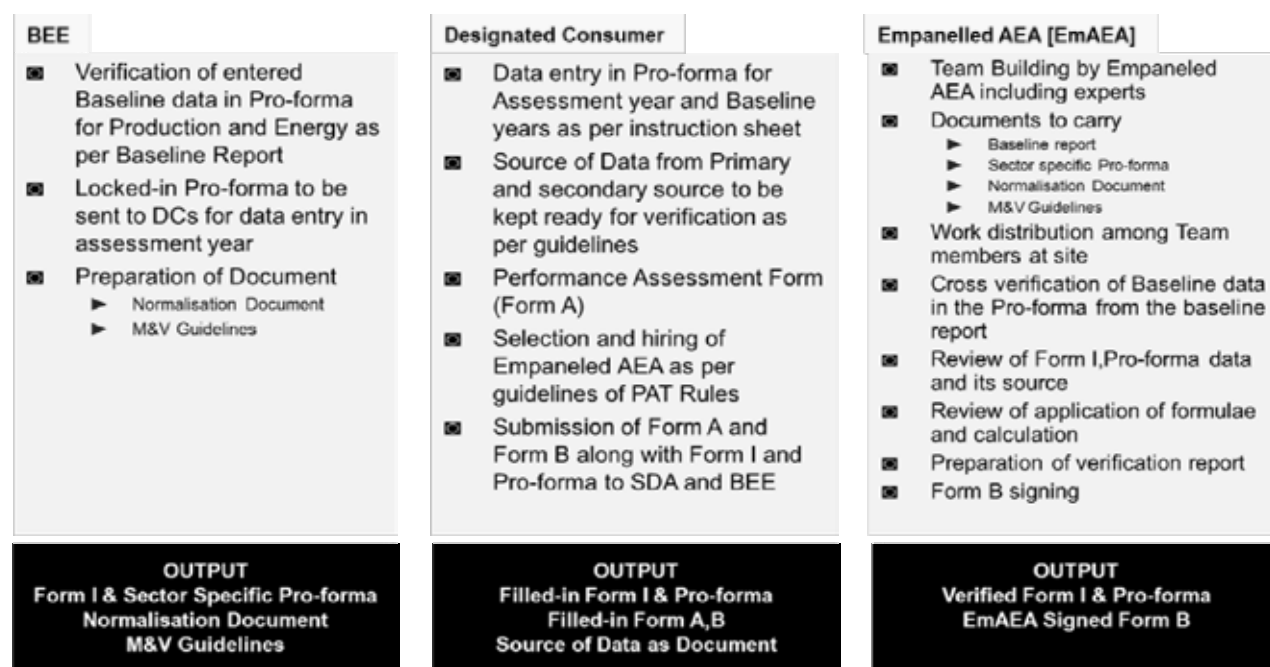



78. Review of assessment year data and its authentic sources:
- i. The verifier shall ask the filled in Sector Specific Pro-forma with Form 1 from the Designated Consumer along with authentic documentary evidence
  - ii. In case DC reports some error; Interlinking or calculation error, these are to be reported back to BEE by the EmAEA with proper justification. BEE will send the rectified Pro-forma to DC through e-mail.
  - iii. EmAEA shall start the verification of Pro-forma referring to the documents provided by DC
  - iv. The guidelines as relevant to the data source are tabulated for different sections in Table 3 to 13 for Designated Consumers of sectors other than Thermal Power Plants. The instruction sheet of Thermal Power Plant sector may be referred for detailed documentation requirement.
  - v. EmAEA may seek other documents relevant to the process of M&V as well apart from the documents mentioned in the guidelines for his satisfaction.
  - vi. EmAEA should include a writeup on Fuel Analysis report, internally or externally, in the Verification Report
  - vii. Data sampling method could be performed on sources of data, so that Operator's Log book/Log Sheet data/Shift Report (Basic data Entry Point particularly for Lab test/Production/External reasons etc) could be verified in a loop of verifying the source document. EmAEA is advised to verify random sampling of data up to the primary source for some of the major parameters, affecting SEC of the Plant, which will be included in the Verification Report
- viii. In case of discrepancies between authentic document provided by DC and the Pro-forma, the same to be recorded in the EmAEA's verification report with justification if any from DC's and EmAEA.
79. Review of Energy Savings Projects
- i. In terms of Rule 7 of PAT Rules 2012 on Quarterly, Yearly and EOC<sup>6</sup> internal data reports prepared by the Designated Consumer
  - ii. In terms of Internal Audit reports prepared and maintained by the Designated Consumer
  - iii. In terms of measures adopted for energy conservation and quantity of energy saved and investment made by the Designated Consumer covering the relevant cycle
  - iv. Through Photographs, Screenshots in support of measures implemented in each year, if feasible
  - v. Through Percentage improvement in energy savings achieved in every year following the baseline year until the target year
  - vi. Verification & validation based on evaluation of implemented EE projects through commissioning and procurement documents
  - vii. Site visit to some of the implemented EE projects for verification and validation
  - viii. Establish linkage of expected results of projects on reduction of GtG SEC

---

<sup>6</sup> EOC: End of Cycle



- ix. Identify SEC reduction reasons in the Verification Report
  - 80. Review of Formulae and its application
    - i. EmAEA to review the formulae used in the Pro-forma with Normalisation factor sheets and its applications; Errors are to be reported immediately to BEE.
    - ii. EmAEA to review the formulae and calculation used to arrive certain data filled in the Pro-forma by Designated Consumer and documented properly in the Verification Report
  - 81. Verification through Personnel Interviews, site visits and cross checking the same with the filled in data in Sector Specific Pro-forma
- 4.3.4. Primary and Secondary source of Documentation**
- 82. For verification process, the DC shall provide all necessary information, supporting documents and access to the Plant site to EmAEA. It will be the responsibility of the EmAEA to maintain the confidentiality of the data collected and not to use for any other purpose except for the PAT scheme.
  - 83. The data submitted for verification and other figure for SEC calculation of any unit has to be in line with the units declared production and consumption figures as per the statutory financial audit and declaration in their annual report.
  - 84. EmAEA, while verifying the SEC calculation should also cross verify the input figures based on the procurement plans and physical receipts.
  - 85. The transit and handling losses have to be within the standard norms allowable under financial audit.
  - 86. Guidelines on sources of data for Designated Consumer and EmAEA:
    - a. The general guidelines for the sectors other than Thermal Power Plants sector are tabulated in Table 3 to 13 in subsequent pages.
    - b. For Thermal Power Plant sector, sector specific pro-forma shall be referred
    - c. Designated Consumer and EmAEA may also refer the guidelines provided in the Instruction sheet attached with the Sector Specific Pro-forma.
  - 87. The general guidelines on sources of data are mentioned below. In case of any discrepancies, EmAEA may seek further field document or Equipment/ Section Log sheets for particular data verification

**Table 3: Production and Capacity Utilisation details**

Sr No	Details	Unit	Frequency of record	Primary Documents from where the information can be sourced and to be kept ready for verification by Accredited Energy Auditor	Secondary Documents from where the information can be sourced and to be kept ready for verification by Accredited Energy Auditor
<b>Production and capacity utilization details</b>					
1	Production Capacity of a Plant/section/line/unit	Tonne	Annual	1) OEM Document of line/unit/equipment capacity 2) Enviromental Consent to establish/operate document 3) DoF Communication	1) Equipment/Section wise capacity document from OEM 2) Capacity calculation document submitted for Enviromental Consent



Sr No	Details	Unit	Frequency of record	Primary Documents from where the information can be sourced and to be kept ready for verification by Accredited Energy Auditor	Secondary Documents from where the information can be sourced and to be kept ready for verification by Accredited Energy Auditor
2	Production of a Plant/ section/line/unit	Tonne	Continuous, Hourly, Daily, Monthly	1) Log Sheet 2) DCS/CCR/ SCADA Report/ Trends 3) DPR 4) MPR 5) SAP Entry in PP/SD module 6) Excise record (ER1) 7) Annual Report 8) TOP	1)Storage Level 2) Feeding Weigh feeders 3) Belt Weigher 4) Solid flow meter 5) Counters
3	Production of Intermediate/ Semifinished Product/Other product	Tonne	Continuous, Hourly, Daily, Monthly	1) Log Sheet 2) DCS/CCR/ SCADA Report/ Trends 3) DPR 4) MPR 5) SAP Entry in PP/SD module 6) Excise record (ER1) 7) Annual Report 8) TOP	1)Storage Level 2) Feeding Weighfeeders 3) Belt Weigher 4) Solid flow meter 5) Counters
4	Opening stock of Intermediary product	Tonne	Daily, Monthly	1) Inventory Report 2) Excise Document (ER1)3) Stores Entry 4) SAP Entry in MM/ PP/SD module 5) Annual Financial report 6) TOP	1) Field Inventory 2) Storage Level
5	Closing Stock of intermediary product	Tonne	Daily, Monthly	1) Inventory Report 2) Excise Document (ER1)3) Stores Entry 4) SAP Entry in MM/ PP/SD module 5) TOP	1) Field Inventory
6	Export of Intermediary Product	Tonne	Daily, Monthly	1) Excise Document 2) Stores receipt 3) SAP Entry in FI/ SD Module 4) Annual Report 5) TOP	1) Internal material Transfer Records
7	Import of Intermediary Product	Tonne	Daily, Monthly	1) Excise Document 2) Stores receipt 3) SAP Entry in FI/ SD Module 4) Annual Report 5) TOP	1) Internal material Transfer Records
8	Raw material consumption if any	Tonne	Daily, Monthly	1)Lab Product Test Report 2) DPR 3) MPR 4) SAP Entry in MM/PP module 5) Raw material stock entry (Stores) 6) TOP	1) Lab Testing Register 2) Closing and opening stock
9	Thermal Energy Consumption of section/Unit/Product	Tonne	Daily, Monthly	1)Fuel Weighfeeder 2) Fuel Flow Meter 3) DPR 4) MPR 5) SAP Entry in MM/PP module 6) TOP	1)Storage Level 2) Feeding Weigh feeders 3) Belt Weigher 4) Solid flow meter
10	Electrical Energy Consumption of section/Unit/Product	Tonne	Daily, Monthly	1) Energy Management System 2) Equipment List Major Eqp section 3) DPR 4) SAP Entry in MM/PP module 6) TOP	1)Storage Level 2) Feeding Weigh feeders 3) Belt Weigher 4) Solid flow meter



**Table 4: Major Equipment capacity and Operating SEC**

Sr No	Details	Unit	Frequency of record	Primary Documents from where the information can be sourced and to be kept ready for verification by Accredited Energy Auditor	Secondary Documents from where the information can be sourced and to be kept ready for verification by Accredited Energy Auditor
Major Eqp Capacity and Operating SEC					
1	Major Eqp wise production in Tonne.	Tonne	Continuous, Hourly, Daily, Monthly	1) Log Sheet 2) CCR SCADA Report/ Trends 3) DPR 4) MPR 5) SAP Entry in MM/PP module	1)Storage Level 2) Feeding Weigh feeders 3) Belt Weigher 4) Solid flow meter
2	Operating Major Eqp thermal SEC (Total thermal energy consumed in Major Eqp/ total Major Eqp production) in kcal/ kg Intermediary Product.	Kcal/ kg or kcal/ Tonne	Continuous, Hourly, Daily, Monthly	1)Fuel Weighfeeder 2) Fuel Flow Meter 3) DPR 4) MPR 5) SAP Entry in MM/PP module	1)Storage Level 2) Feeding Weigh feeders 3) Belt Weigher 4) Solid flow meter
3	Operating Major Eqp electrical SEC (Total electricity consumed in Major Eqp/ total Major Eqp production) in kWh/ kg Intermediary Product.	Kwh/ Tonne	Continuous, Hourly, Daily, Monthly	1) Energy Management System 2) Equipment List Major Eqp section 3) DPR 4) SAP Entry in MM/PP module	1)Electrical Meter Record for Major Eqp section
4	Major Eqp wise annual running hours.	Hrs	Continuous, Hourly, Daily, Monthly	1) Major Eqp Log sheet 2) DPR 3) MPR 4) DCS/CCR/DCS Trends	1)Major Eqp Shift operator's Log Register 2) Breakdown report
5	Annual Hot-Hot start in Nos	Nos	Continuous, Hourly, Daily, Monthly	1) Major Eqp Log sheet 2) DPR 3) MPR 4) DCS/CCR/DCS Trends	1)Major Eqp Shift operator's Log Register 2) Breakdown report
6	Total annual Hot-Cold Stoppage Hours for Major Eqp due to external factor <sup>7</sup>	Hrs	Continuous, Hourly, Daily, Monthly	1) Major Eqp Log sheet 2) DPR 3) MPR 4) DCS/CCR/DCS Trends	1)Major Eqp Shift operator's Log Register 2) Breakdown report
7	Total annual Hot-Cold Stoppage Nos for Major Eqp due to external factor	Nos	Continuous, Hourly, Daily, Monthly	1) Major Eqp Log sheet 2) DPR 3) MPR 4) DCS/CCR/DCS Trends	1)Major Eqp Shift operator's Log Register 2) Breakdown report

<sup>7</sup> External Factor: Market Demand, Grid Failure (Where CPP is not Sync with Grid), Raw material unavailability, Natural Disaster, Rioting or Social unrest, Major change in government policy hampering plant's process system, Any unforeseen circumstances not controlled by plant management



Sr No	Details	Unit	Frequency of record	Primary Documents from where the information can be sourced and to be kept ready for verification by Accredited Energy Auditor	Secondary Documents from where the information can be sourced and to be kept ready for verification by Accredited Energy Auditor
8	Total annual Electrical Energy Consumption for Hot-Cold Stoppage for Major Eqp due to external factor in Lakh kWh	Lakh kWh	Continuous, Hourly, Daily, Monthly	1) Energy Meter Reading for Major Eqp Section 2) Major Eqp Log sheet 3) DPR 4) MPR 5) CCR SCADA Trends	1)Major Eqp Shift operator's Log Register 2) Breakdown report
9	Total annual Cold-Hot Start Hours for Major Eqp due to external factor	Hrs	Continuous, Hourly, Daily, Monthly	1) Major Eqp Log sheet 2) Major Eqp Shift operator's Log Register 3) DPR 4) MPR 5) CCR SADA Trends	1)Major Eqp Shift operator's Log Register 2) Breakdown report
10	Total annual Cold-Hot Start Nos for Major Eqp due to external factor	Nos	Continuous, Hourly, Daily, Monthly	1) Major Eqp Log sheet 2) Major Eqp Shift operator's Log Register 3) DPR 4) MPR 5) DCS/CCR/DCS Trends	1)Major Eqp Shift operator's Log Register 2) Breakdown report
11	Total annual Electrical Energy Consumption for Cold-Hot Start for Major Eqp due to external factor in Lakh kWh	Lakh kWh	Continuous, Hourly, Daily, Monthly	1) Energy Meter Reading for Major Eqp Section 2) Major Eqp Log sheet 3) DPR 4) MPR 5) DCS/CCR/DCS Trends	1)Major Eqp Shift operator's Log Register 2) Breakdown report
12	Annual Cold-Hot Start in Nos due to internal factors	Nos	Continuous, Hourly, Daily, Monthly	1) Major Eqp Log sheet 2) Major Eqp Shift operator's Log Register 3) DPR 4) MPR 5) DCS/CCR/DCS Trends	1)Major Eqp Shift operator's Log Register 2) Breakdown report

**Table 5: Boiler Details (Process and Co-Generation)**

Sr No	Details	Unit	Frequency of record	Primary Documents from where the information can be sourced and to be kept ready for verification by Accredited Energy Auditor	Secondary Documents from where the information can be sourced and to be kept ready for verification by Accredited Energy Auditor
<b>Boiler Details (Process/Co-Gen)</b>					
1	Type			1) OEM Document	
2	Rated Capacity	TPH	Annual	1) OEM document on Boiler Capacity 2) Predicted performance Data (PPD) for Boiler 3) Environmental Consent to Operate	1) Capacity calculation submitted for Environmental Consent
3	Total Steam Generation	Ton	Continuous, Hourly, Daily, Monthly	1) Log Sheet 2) DCS/ SCADA Trend 3) DGR 4)MGR 5) SAP Entry in PP/PM Module	1) Steam Flow Meter 2) Process steam Consumption report 3) Log Book





Sr No	Details	Unit	Frequency of record	Primary Documents from where the information can be sourced and to be kept ready for verification by Accredited Energy Auditor	Secondary Documents from where the information can be sourced and to be kept ready for verification by Accredited Energy Auditor
4	Running hours	Hrs	Continuous, Hourly, Daily, Monthly	1) Log Sheet 2) DCS/ SCADA Trend 3) DGR 4)MGR 5) SAP Entry in PP/PM Module	1) Hour Meter 2) Log book
5	Coal Consumption	Tonne	Continuous, Hourly, Daily, Monthly	1) Log Sheet 2) DCS/ SCADA Trend 3) DGR 4)MGR 5) SAP Entry in PP/PM Module	1) Weigh Feeder 2) Solid flow Meter 3) Coal Storage register 4) Storage Level
6	GCV of Coal	kcal/kg	Daily, Monthly, Yearly	1) Daily Internal Report from Lab on Fuel Proximate Analysis performed on each lot. 2) Test Certificate from Government Accredited lab. (Plant to maintain minimum 1 sample test in a quarter for Proximate and Ultimate Analysis i.e. 4 test certificates in a year for each fuel in case of CPP/Cogen Fuel, for Process Fuel 1 sample test in a quarter for Proximate Analysis) 3) Purchase Order, where guaranteed GCV range is mentioned	1) Lab Register on Fuel Testing for Proximate Analysis 2) Calibration Record of instrument used for testing
7	Type of Fuel – 2 Name : Consumption	Tonne	Continuous, Hourly, Daily, Monthly	1) DGR 2) MGR 3) CPP/ Cogen Log Sheet 4) SAP Entry in MM/PP/FI module 5) Annual Report	1)Belt Weigher before Fuel Bunker
8	GCV of any Fuel -2	kcal/kg	Daily, Monthly, Yearly	1) DGR 2) MGR 3) Lab Test Report	1) Lab Register on Fuel Testing for Proximate Analysis 2) Calibration Record of instrument used for testing
9	Type of Fuel – 3 Name : Consumption	Tonne	Continuous, Hourly, Daily, Monthly	1) DGR 2) MGR 3) CPP/ Cogen Log Sheet 4) SAP Entry in MM/PP/FI module 5) Annual Report	1)Belt Weigher before Fuel Bunker
10	GCV of any Fuel -3	kcal/kg	Daily, Monthly, Yearly	1) DGR 2) MGR 3) Lab Test Report	1) Lab Register on Fuel Testing for Proximate Analysis 2) Calibration Record of instrument used for testing
11	Type of Fuel – 4 Name : Consumption	Tonne	Continuous, Hourly, Daily, Monthly	1) DGR 2) MGR 3) CPP/ Cogen Log Sheet 4) SAP Entry in MM/PP/FI module 5) Annual Report	1) Belt Weigher before Fuel Bunker



Sr No	Details	Unit	Frequency of record	Primary Documents from where the information can be sourced and to be kept ready for verification by Accredited Energy Auditor	Secondary Documents from where the information can be sourced and to be kept ready for verification by Accredited Energy Auditor
12	GCV of any Fuel -4	kcal/kg	Daily, Monthly, Yearly	1) DGR 2) MGR 3) Lab Test Report	1) Lab Register on Fuel Testing for Proximate Analysis 2) Calibration Record of instrument used for testing
13	Feed water Temperature	°C	Continuous, Hourly, Daily, Monthly	1) DGR 2) DCS/SCADA Trends	
14	Operating Efficiency	%	Continuous, Hourly, Daily, Monthly	1) Indirect Method or Direct method calculation	
15	SH Steam outlet Pressure (Operating)	kg/cm <sup>2</sup>	Continuous, Hourly, Daily, Monthly	1) DGR 2) DCS/SCADA Trends	1) Field Pressure Meter
16	SH Steam outlet Temperature (Operating)	°C	Continuous, Hourly, Daily, Monthly	1) DGR 2) DCS/SCADA Trends	1) Field Temperature Meter
17	SH Steam Enthalpy (Operating)	kcal/kg	Continuous, Hourly, Daily, Monthly	1) Steam Table	
18	Design Efficiency	%	Yearly	1) OEM document on Boiler Efficiency 2) Predicted performance Data (PPD) for Boiler	1) Design Calculation

**Table 6: Electricity from Grid/Others, Renewable Purchase Obligation, Notified Figures**

Sr No	Details	Unit	Frequency of record	Primary Documents from where the information can be sourced and to be kept ready for verification by Accredited Energy Auditor	Secondary Documents from where the information can be sourced and to be kept ready for verification by Accredited Energy Auditor
<b>Electricity from Grid / Other (Including Colony and Others) / Renewable Purchase obligation/Notified Figures</b>					
1	Annual electricity purchase from the grid	Lakh kWh	Daily, Monthly	1) Monthly Electricity Bills from Grid 2) Internal Meter reading records for grid incomer	Energy Management System



Sr No	Details	Unit	Frequency of record	Primary Documents from where the information can be sourced and to be kept ready for verification by Accredited Energy Auditor	Secondary Documents from where the information can be sourced and to be kept ready for verification by Accredited Energy Auditor
2	Renewable electricity consumption through wheeling	Lakh kWh	Daily, Monthly	1) Open Access records 2) Electricity Bills for Renewable energy 3) Renewable Purchase Obligation document	Energy Management System
3	Electricity consumption from CPP located outside of the plant boundary though wheeling	Lakh kWh	Daily, Monthly	1) Open Access records 2) Electricity Bills (for Wheeling)	Energy Management System
4	Renewable Purchase obligation of plant for the current year in % (Solar and Non-Solar).	%	Yearly	1) Renewable Purchase Obligation document	
5	Renewable Purchase obligation of plant for the current year in Lakh kWh (Solar and Non-Solar).	Lakh kWh	Yearly	1) Renewable Purchase Obligation document	
6	Renewable Purchase obligation of plant for the current year in MW (Solar and Non-Solar).	MW	Yearly	1) Renewable Purchase Obligation document	
7	Renewable Energy Generator Capacity in MW as approved by MNRE	MW	Yearly	1)'Certificate for Registration' to the concerned Applicant as 'Eligible Entity' confirming its entitlement to receive Renewable Energy Certificates for the proposed RE Generation project	
8	Quantum of Renewable Energy Certificates (REC) obtained as a Renewable Energy Generator (Solar & Non-Solar) in terms of REC equivalent to 1 MWh	Nos	Yearly	1) Renewable Energy Certificates	
9	Quantum of Energy sold in terms of preferential tariff under REC Mechanism in MWh	Nos	Lot, Yearly	1)PowerPurchaseAgreement (PPA) for the capacity related to such generation to sell electricity at preferential tariff determined by the Appropriate Commission	



Sr No	Details	Unit	Frequency of record	Primary Documents from where the information can be sourced and to be kept ready for verification by Accredited Energy Auditor	Secondary Documents from where the information can be sourced and to be kept ready for verification by Accredited Energy Auditor
10	Plant connected load	kW	Monthly	1) L-Form document 2) Electrical Inspectorate record	1) Total connected Load (TCL) of Plant 2) Equipment List
11	Plant contract demand with utility i	kVA	Monthly	1) Monthly Electricity Bills from Utility	
12	DCs Notified Specific Energy Consumption in TOE/T for Baseline Year	TOE/T		1) Notification S.O.687 dated 31/03/2012	
13	DCs Target Specific Energy Consumption in TOE/T for Target year	TOE/T		1) Notification S.O.687 dated 31/03/2012	
14	Equivalent Major Product Output in tonne as per PAT scheme Notification	Tonne		1) Notification S.O.687 dated 31/03/2012	

**Table 7: Own generation through Captive Power Plants**

Sr No	Details	Unit	Frequency of record	Primary Documents from where the information can be sourced and to be kept ready for verification by Accredited Energy Auditor	Secondary Documents from where the information can be sourced and to be kept ready for verification by Accredited Energy Auditor
<b>Own Generation through CPP (STG/GG/GT/WHRB/DG)</b>					
1	Selection is required from the drop down list for grid connectivity with grid (Yes/No)	Yes/No			
2	Installed capacity of all the Units in MW.	MW	Annual	1) OEM document for capacity 2) Rating plate of Generator	1) Capacity Enhancement document 2) R&M document
3	Gross unit generation of all the Units in Lakh kWh.	Lakh kWh	Continuous, Hourly, daily, Monthly	1) Daily Generation Report 2) Monthly Generation Report 3) CPP main energy meter reading record 4) Energy Management System data	1) Energy Meter
4	Auxiliary power consumption (APC) in %.	%	Continuous, Hourly, daily, Monthly	1) Daily Power Report 2) Monthly Power Report 3) CPP main energy meter reading record 4) Energy Management System data	1) Energy Meter 2) Equipment List



Sr No	Details	Unit	Frequency of record	Primary Documents from where the information can be sourced and to be kept ready for verification by Accredited Energy Auditor	Secondary Documents from where the information can be sourced and to be kept ready for verification by Accredited Energy Auditor
5	Design Heat Rate of all the Units in kcal/kWh.	Kcal/kWh	Annual	1) OEM document on designed heat rate	1) PG test document
6	Annual running hours of all the units.	Hrs	Continuous, Hourly, daily, Monthly	1) Daily Generation Report 2) Monthly Generation Report 3) Energy Management System data	1) Break down report 3) Operators Shift Register
7	Annual available hours of respective unit. Ex. If a unit commissions on 1st Oct, then available hour for the year will be 4380 hours	Hrs	Continuous, Hourly, daily, Monthly	1) Daily Generation Report 2) Monthly Generation Report 3) Energy Management System data	1) Break down report 3) Operators Shift Register
8	Break down hrs due to internal, Planned and external factor for calculating Plant Availability Factor	Hrs	Hourly, daily, Monthly	1) CPP Log Sheet 2) Operators log Register 3) Daily generation Report 4) Monthly Generation Report 5) Energy Management System data 6) Refer Sr. No: N	1) Operator's Shift Register 2) CPP Break down analysis Report
9	No of hrs per annum during which Plant run on low load due to Internal Factors/ Breakdown in Plant (Average weighted hours of all the units)	Hrs	Hourly, daily, Monthly	1) CPP Log Sheet 2) Operators log Register 3) Daily generation Report 4) Monthly Generation Report 5) Energy Management System data 6) Refer Sr. No: N	1) Operator's Shift Register 2) CPP Break down analysis Report
10	No of hrs per annum during which Plant runs on low load due to Fuel Unavailability/ Market demand/ External Condition (Average weighted hours of all the units)	Hrs	Hourly, daily, Monthly	1) CPP Log Sheet 2) Operators log Register 3) Daily generation Report 4) Monthly Generation Report 5) Energy Management System data 6) Refer Sr. No: N	1) Operator's Shift Register 2) CPP Break down analysis Report
<b>Through Co-Generation</b>					
1	Grid Connected	Yes/ No			
2	Installed Capacity	MW	Annual	1) OEM document for capacity 2) Rating plate of Generator	1) Capacity Enhancement document 2) R&M document
3	Annual Gross Unit generation	Lakh kWh	Continuous, Hourly, daily, Monthly	1) Daily Generation Report 2) Monthly Generation Report 3) CPP main energy meter reading record 4) Energy Management System data	1) Energy Meter



Sr No	Details	Unit	Frequency of record	Primary Documents from where the information can be sourced and to be kept ready for verification by Accredited Energy Auditor	Secondary Documents from where the information can be sourced and to be kept ready for verification by Accredited Energy Auditor
4	Auxiliary Power Consumption	Lakh kWh	Continuous, Hourly, daily, Monthly	1) Daily Power Report 2) Monthly Power Report 3) CPP main energy meter reading record 4) Energy Management System data	1) Energy Meter 2) Equipment List
5	Design Heat Rate	kcal/kWh	Annual	1) OEM document on designed heat rate	1) PG test document
6	Running Hours	Hrs	Continuous, Hourly, daily, Monthly	1) Daily Generation Report 2) Monthly Generation Report 3) Energy Management System data Inlet Steam	1) Break down report 3) Operators Shift Register
7	Total Steam Flow	Ton	Continuous, Hourly, daily, Monthly	1) Daily Generation Report 2) Monthly Generation Report 3) DCS/SCADA Records	1) Makeup water Reading 2) Field Steam Flow meter reading
8	Avg. Steam Pressure	Kg/cm <sup>2</sup>	Continuous, Hourly, daily, Monthly	1) Daily Generation Report 2) Monthly Generation Report 3) DCS/SCADA Records	1) Field Pressure Meter
9	Avg. Steam Temperature	°C	Continuous, Hourly, daily, Monthly	1) Daily Generation Report 2) Monthly Generation Report 3) DCS/SCADA Records	1) Field Temperature Meter
10	Avg. Steam Enthalpy	kcal/kg	Continuous, Hourly, daily, Monthly	1) Steam Table	
<b>Steam Extraction 1 (MP)</b>					
11	Total Steam Flow (at the Header)	Ton	Continuous, Hourly, daily, Monthly	1) Daily Generation Report 2) Monthly Generation Report 3) DCS/SCADA Records	1) Makeup water Reading 2) Field Steam Flow meter reading
12	Avg. Steam Pressure (at the Header)	Kg/cm <sup>2</sup>	Continuous, Hourly, daily, Monthly	1) Daily Generation Report 2) Monthly Generation Report 3) DCS/SCADA Records	1) Field Pressure Meter
13	Avg. Steam Temperature (at the Header)	°C	Continuous, Hourly, daily, Monthly	1) Daily Generation Report 2) Monthly Generation Report 3) DCS/SCADA Records	1) Field Temperature Meter
14	Avg. Steam Enthalpy (at the Header)	kcal/kg	Continuous, Hourly, daily, Monthly	1) Steam Table	



Sr No	Details	Unit	Frequency of record	Primary Documents from where the information can be sourced and to be kept ready for verification by Accredited Energy Auditor	Secondary Documents from where the information can be sourced and to be kept ready for verification by Accredited Energy Auditor
<b>Steam Extraction 2 (LP)</b>					
15	Total Steam Flow (at the Header)	Ton	Continuous, Hourly, daily, Monthly	1) Daily Generation Report 2) Monthly Generation Report 3) DCS/SCADA Records	1) Makeup water Reading 2) Field Steam Flow meter reading
16	Avg. Steam Pressure (at the Header)	Kg/cm <sup>2</sup>	Continuous, Hourly, daily, Monthly	1) Daily Generation Report 2) Monthly Generation Report 3) DCS/SCADA Records	1) Field Pressure Meter
17	Avg. Steam Temperature (at the Header)	°C	Continuous, Hourly, daily, Monthly	1) Daily Generation Report 2) Monthly Generation Report 3) DCS/SCADA Records	1) Field Temperature Meter
18	Avg. Steam Enthalpy (at the Header)	kcal/kg	Continuous, Hourly, daily, Monthly	1) Steam Table	
<b>Steam Condensing</b>					
18	Total Exhaust Steam Flow	Ton	Continuous, Hourly, daily, Monthly	1) Daily Generation Report 2) Monthly Generation Report 3) DCS/SCADA Records	1) Makeup water Reading 2) Field Steam Flow meter reading
20	Exhaust Steam Vacuum	Kg/cm <sup>2</sup> (a)	Continuous, Hourly, daily, Monthly	1) Daily Generation Report 2) Monthly Generation Report 3) DCS/SCADA Records	1) Field Pressure Meter
<b>Power from dedicated line</b>					
1	Power wheeled through dedicated line in MW (average for the year)	MW	Hourly, daily, monthly	1) Energy Meter reading for nos of hours, 2) Daily Power Report	Energy Meter
2	Electricity wheeled in a year in lakh kWh	Lakh kWh		1) Separate Energy Meter Reading 2) Daily and Monthly Power Report	
3	Heat Rate of wheeled imported Electricity in kcal/kWh	kcal/kWh	daily, Monthly	1) Power Purchase Agreement 2) DGR of Sister concerned from where the power is wheeled 3)	1) Primary document from the sister concern 2) Excise document of purchase electricity
<b>Power Export and Colony/Others consumption</b>					



Sr No	Details	Unit	Frequency of record	Primary Documents from where the information can be sourced and to be kept ready for verification by Accredited Energy Auditor	Secondary Documents from where the information can be sourced and to be kept ready for verification by Accredited Energy Auditor
1	Quantity of electricity sold to the grid in Lakh kWh.	Lakh kWh	Continuous, Hourly, daily, Monthly	1) Daily Power Report 2) Monthly Power Report 3) Export main energy meter reading record 4) Energy Management System data 5) Monthly Export bill receipt sent to utility	Export Energy Meter
2	Quantity of electricity consumed in colony / other in Lakh kWh.	Lakh kWh	Continuous, Hourly, daily, Monthly	1) Daily Power Report 2) Monthly Power Report 3) Colony/other main energy meter reading record 4) Energy Management System data	1) colony/Others meter

**Table 8: Solid Fuel Consumption**

Sr No	Details	Unit	Frequency of record	Primary Documents from where the information can be sourced and to be kept ready for verification by Accredited Energy Auditor	Secondary Documents from where the information can be sourced and to be kept ready for verification by Accredited Energy Auditor
<b>Solid Fuel Consumption</b>					
<b>A. Coal (Indian) / Petcoke/ Coal (Imported) / Coal (Lignite)/Coal 1/Coal 2/Coal 3/ Coal 4 (Other Solid Fuel)/ Dolachar/Coal fines/Met Coke/Coke Breeze /Nut coke/Lump Coke (Imported)</b>					
1	Landed cost of Solid Fuel i.e. Basic Cost+All Taxes + Freight. The landed cost of last purchase order in the financial year	Rs./ MT	Annual	1) Purchase Order for basic rates and taxes 2) Freight document for rates	
2	Gross calorific value (As Fired Basis <sup>8</sup> ) of solid fuel consumed for power generation	kcal/ kg	Lot, Daily, Monthly, Quarterly	1) Daily Internal Report from Lab on Fuel Proximate Analysis performed on each lot. 2) Test Certificate from Government Accredited lab. (Plant to maintain minimum 1 sample test in a quarter for Proximate and Ultimate Analysis i.e. 4 test certificates in a year for each fuel in case of CPP/Cogen/WHRB Fuel, for Process Fuel 1 sample test in a quarter for Proximate Analysis) 3) Purchase Order, where guaranteed GCV range is mentioned	1) Lab Register on Fuel Testing for Proximate Analysis 2) Calibration Record of instrument used for testing

<sup>8</sup> Location of sampling: As fired Fuel after the Grinding Mill





Sr No	Details	Unit	Frequency of record	Primary Documents from where the information can be sourced and to be kept ready for verification by Accredited Energy Auditor	Secondary Documents from where the information can be sourced and to be kept ready for verification by Accredited Energy Auditor
3	Gross calorific value (As Fired Basis <sup>9</sup> ) of solid fuel consumed in the process	kcal/kg	Lot, Daily, Monthly, Quarterly	1) Daily Internal Report from Lab on Fuel Proximate Analysis performed on each lot. 2) Test Certificate from Government Accredited lab. (Plant to maintain minimum 1 sample test in a quarter for Proximate and Ultimate Analysis i.e. 4 test certificates in a year for each fuel in case of CPP/Cogen/WHRB Fuel, for Process Fuel 1 sample test in a quarter for Proximate Analysis) 3) Purchase Order, where guaranteed GCV range is mentioned	1) Lab Register on Fuel Testing for Proximate Analysis 2) Calibration Record of instrument used for testing
4	Annual solid fuel quantity purchased	Tonne	Lot, Daily, Monthly, Yearly	1) Purchase Order 2) Stores Receipt 3) SAP Entry in MM/PP/FI module 4) Annual Report	1) Stores Receipt Register
5	Annual solid fuel moisture % (As Received Basis)	%	Lot, Daily, Monthly, Yearly	1) Daily Internal Report from Lab on Fuel Proximate Analysis performed on each lot. 2) Purchase Order, where guaranteed % moisture range is mentioned	1) Lab Register on Fuel Testing for Proximate Analysis 2) Calibration Record of instrument used for testing
6	Annual solid fuel quantity consumed in power generation	Tonne	Hourly, Daily and Monthly	1) DPR 2) MPR 3) CPP/Cogen/WHRB Log Sheet 4) SAP Entry in MM/PP/FI module 5) Annual Report	1) Belt Weigher before Coal Bunker
7	Annual solid fuel quantity consumed in process	Tonne	Hourly, Daily and Monthly	1) DPR 2) MPR 3) Major Eqp Log Sheet 4) SAP Entry in MM/PP/FI module 5) Annual Report	1) Belt Weigh Feeder 2) Solid Flow Meter
<b>B. Biomass and other renewable solid fuel / Solid waste</b>					
1	Landed cost of Solid Fuel i.e. Basic Cost+All Taxes + Freight. The landed cost of last purchase order in the financial year	Rs./ Tonne	Yearly	1) Purchase Order for basic rates and taxes 2) Freight document for rates	

<sup>9</sup> Location of sampling: As fired Fuel after the Grinding Mill



Sr No	Details	Unit	Frequency of record	Primary Documents from where the information can be sourced and to be kept ready for verification by Accredited Energy Auditor	Secondary Documents from where the information can be sourced and to be kept ready for verification by Accredited Energy Auditor
2	Gross calorific value of biomass / solid waste	kcal/kg	Lot, Daily, Monthly, Quarterly	1) Daily Internal Report from Lab on Fuel Proximate Analysis performed on each lot. 2) Test Certificate from Government Accredited lab (NABL). (Plant to maintain minimum 1 sample test in a quarter for Proximate and Ultimate Analysis i.e. 4 test certificates in a year for each fuel in case of CPP Fuel, for Process Fuel 1 sample test in a quarter for Proximate Analysis) 3) Purchase Order, where guaranteed GCV range is mentioned	1) Lab Register on Fuel Testing for Proximate Analysis 2) Calibration Record of instrument used for testing
3	Annual biomass/solid waste quantity purchased	Tonne	Lot, Daily, Monthly, Yearly	1) Purchase Order 2) Stores Receipt 3) SAP Entry in MM/PP/FI module 4) Annual Report	1) Stores Receipt Register
4	Annual solid fuel moisture % (As Received Basis)	%	Lot, Daily, Monthly, Yearly	1) Daily Internal Report from Lab on Fuel Proximate Analysis performed on each lot. 2) Purchase Order, where guaranteed % moisture range is mentioned	1) Lab Register on Fuel Testing for Proximate Analysis 2) Calibration Record of instrument used for testing
5	Annual biomass/solid waste Consumed in power generation	Tonne	Hourly, Daily and Monthly	1) DPR 2) MPR 3) CPP Log Sheet 4) SAP Entry in MM/PP/FI module 5) Annual Report	1) Belt Weigher before Coal Bunker
6	Annual biomass/solid waste consumed in processing	Tonne	Hourly, Daily and Monthly	1) DPR 2) MPR 3) Major Eqp Log Sheet 4) SAP Entry in MM/PP/FI module 5) Annual Report	1) Belt Weigh Feeder 2) Solid Flow Meter



**Table 9: Liquid Fuel Consumption**

Sr No	Details	Unit	Frequency of record	Primary Documents from where the information can be sourced and to be kept ready for verification by Accredited Energy Auditor	Secondary Documents from where the information can be sourced and to be kept ready for verification by Accredited Energy Auditor
<b>Liquid Fuel Consumption</b>					
<b>A</b>	<b>Furnace Oil</b>				
1	Landed cost of Solid Fuel i.e. Basic Cost+All Taxes + Freight. The landed cost of last purchase order in the financial year	Rs/ Tonne	Annual	1) Purchase Order for basic rates and taxes 2) Freight document for rates	
2	Gross calorific value of furnace oil	kcal/ kg	Lot, Monthly, Yearly	1) Test report from Supplier 2) Internal Test Report from lab 3) Test report from Government Accredited (NABL) Lab <sup>10</sup> 4) Standard Value as per Notification	Lab Register
3	Annual furnace oil quantity purchase	kL	Lot, Monthly, Yearly	1) Purchase Order 2) Stores Receipt 3) SAP Entry in MM/PP/FI module 4) Annual Report	Stores Receipt
4	Density of furnace oil	kg/Ltr	Lot, Monthly, Yearly	1) Test report from Supplier 2) Internal Test Report from lab 3) Test report from Government Accredited (NABL) Lab 4) Standard Value as per Notification	Lab Register
5	Furnace oil quantity consumed in DG set for power generation	kL	Daily, Monthly, Yearly	1) Daily Generation Report 2) Monthly Generation Report 3) DG Log Sheet 4) SAP Entry in MM/PP/FI module 5) Annual Report	Flow Meter, Dip measurement in day tank
6	Furnace oil quantity consumed in CPP for power generation in kilo liters.	kL	Daily, Monthly, Yearly	1) Daily Generation Report 2) Monthly Generation Report 3) CPP Log Sheet 4) SAP Entry in MM/PP/FI module 5) Annual Report	Flow Meter, Dip measurement in day tank
7	Furnace oil quantity used in process heating (including Pyro-processing and Product mill Hot Air Generator) in kilo litres.	kL	Daily, Monthly, Yearly	1) DPR 2) MPR 3) Major Eqp Log Sheet 4) Product Mill Log Sheet 5) SAP Entry in MM/PP/FI module 6) Annual Report	Flow Meter, Dip measurement in day tank

<sup>10</sup> Government Accredited Lab: National Accreditation Board for Testing and Calibration Laboratories(NABL Labs)



Sr No	Details	Unit	Frequency of record	Primary Documents from where the information can be sourced and to be kept ready for verification by Accredited Energy Auditor	Secondary Documents from where the information can be sourced and to be kept ready for verification by Accredited Energy Auditor
<b>B</b>	<b>LSHS/HSHS</b>				
1	Landed cost of Solid Fuel i.e. Basic Cost+All Taxes + Freight. The landed cost of last purchase order in the financial year	Rs/ Tonne	Annual	1) Purchase Order for basic rates and taxes 2) Freight document for rates	
2	Gross calorific value of LSHS/HSHS	kcal/ kg	Lot, Monthly, Yearly	1) Test report from Supplier 2) Internal Test Report from lab 3) Test report from Government Accredited Lab 4) Standard Value as per Notification	Lab Register
3	Annual LSHS/HSHS quantity purchase	Tonne	Lot, Monthly, Yearly	1) Purchase Order 2) Stores Receipt 3) SAP Entry in MM/PP/FI module 4) Annual Report	Stores Receipt
4	LSHS/HSHS quantity consumed in DG set for power generation	Tonne	Daily, Monthly, Yearly	1) Daily Generation Report 2) Monthly Generation Report 3) DG Log Sheet 4) SAP Entry in MM/PP/FI module 5) Annual Report	Flow Meter, Dip measurement in day tank
5	LSHS/HSHS quantity consumed in CPP for power generation	Tonne	Daily, Monthly, Yearly	1) Daily Generation Report 2) Monthly Generation Report 3) CPP Log Sheet 4) SAP Entry in MM/PP/FI module 5) Annual Report	Flow Meter, Dip measurement in day tank
6	LSHS/HSHS quantity consumed in process heating.	Tonne	Daily, Monthly, Yearly	1) DPR 2) MPR 3) Major Eqp Log Sheet 4) Product Mill Log Sheet 5) SAP Entry in MM/PP/FI module 6) Annual Report	Flow Meter, Dip measurement in day tank
<b>C</b>	<b>HSD/LDO</b>				
1	Landed cost of Solid Fuel i.e. Basic Cost+All Taxes + Freight. The landed cost of last purchase order in the financial year	Rs./ Tonne	Annual	1) Purchase Order for basic rates and taxes 2) Freight document for rates	
2	the gross calorific value of HSD/LDO	kcal/ kg	Lot, Monthly, Yearly	1) Test report from Supplier 2) Internal Test Report from lab 3) Test report from Government Accredited Lab 4) Standard Value as per Notification	Lab Register



Sr No	Details	Unit	Frequency of record	Primary Documents from where the information can be sourced and to be kept ready for verification by Accredited Energy Auditor	Secondary Documents from where the information can be sourced and to be kept ready for verification by Accredited Energy Auditor
3	Annual HSD/LDO quantity purchase	kL	Lot, Monthly, Yearly	1) Purchase Order 2) Stores Receipt 3) SAP Entry in MM/PP/FI module 4) Annual Report	Stores Receipt
4	Density of HSD/LDO	kg/Ltr	Lot, Monthly, Yearly	1) Test report from Supplier 2) Internal Test Report from lab 3) Test report from Government Accredited Lab 4) Standard Value as per Notification	Lab Register
5	HSD/LDO quantity used in DG set for power generation	kL	Daily, Monthly, Yearly	1) Daily Generation Report 2) Monthly Generation Report 3) DG Log Sheet 4) SAP Entry in MM/PP/FI module 5) Annual Report	Flow Meter, Dip measurement in day tank
6	HSD/LDO quantity used in CPP for power generation	kL	Daily, Monthly, Yearly	1) Daily Generation Report 2) Monthly Generation Report 3) CPP Log Sheet 4) SAP Entry in MM/PP/FI module 5) Annual Report	Flow Meter, Dip measurement in day tank
7	HSD/LDO quantity used in Transportation, if any	kL	Daily, Monthly, Yearly	1) Vehicle Log book 2) Stores Receipt 3) Fuel Dispenser meter reading 3) Work Order for Internal Transportation	
8	HSD/LDO quantity used in process heating	kL	Daily, Monthly, Yearly	1) DPR 2) MPR 3) Major Eqp Log Sheet 4) Product Mill Log Sheet 5) SAP Entry in MM/PP/FI module 6) Annual Report	Flow Meter, Dip measurement in day tank
<b>D</b>	<b>Liquid Waste</b>				
1	Landed cost of Solid Fuel i.e. Basic Cost+All Taxes + Freight. The landed cost of last purchase order in the financial year	Rs/ Tonne	Annual	1) Purchase Order for basic rates and taxes 2) Freight document for rates	
2	Gross calorific value of liquid waste	kcal/ kg	Lot, Monthly, Yearly	1) Test report from Supplier 2) Internal Test Report from lab 3) Test report from Government Accredited Lab 4) Standard Value as per Notification	Lab Register
3	Annual liquid waste quantity purchase	kL	Lot, Monthly, Yearly	1) Purchase Order 2) Stores Receipt 3) SAP Entry in MM/PP/FI module 4) Annual Report	Stores Receipt



Sr No	Details	Unit	Frequency of record	Primary Documents from where the information can be sourced and to be kept ready for verification by Accredited Energy Auditor	Secondary Documents from where the information can be sourced and to be kept ready for verification by Accredited Energy Auditor
4	Density of liquid waste	kg/Ltr	Lot, Monthly, Yearly	1) Test report from Supplier 2) Internal Test Report from lab 3) Test report from Government Accredited Lab 4) Standard Value as per Notification	Lab Register
5	Liquid waste quantity consumed in DG set for power generation	kL	Daily, Monthly, Yearly	1) Daily Generation Report 2) Monthly Generation Report 3) DG Log Sheet 4) SAP Entry in MM/PP/FI module 5) Annual Report	Flow Meter, Dip measurement in day tank
6	Liquid waste quantity consumed in CPP for power generation	kL	Daily, Monthly, Yearly	1) Daily Generation Report 2) Monthly Generation Report 3) CPP Log Sheet 4) SAP Entry in MM/PP/FI module 5) Annual Report	Flow Meter, Dip measurement in day tank
7	Liquid waste quantity consumed in process heating	kL	Daily, Monthly, Yearly	1) DPR 2) MPR 3) Major Eqp Log Sheet 4) Product Mill Log Sheet 5) SAP Entry in MM/PP/FI module 6) Annual Report	Flow Meter, Dip measurement in day tank

**Table 10: Gaseous Fuel Consumption**

Sr No	Details	Unit	Frequency of record	Primary Documents from where the information can be sourced and to be kept ready for verification by Accredited Energy Auditor	Secondary Documents from where the information can be sourced and to be kept ready for verification by Accredited Energy Auditor
<b>Gaseous Fuel Consumption</b>					
<b>A</b>	<b>Natural Gas (CNG/NG/PNG/LNG)</b>				
1	Landed cost of Solid Fuel i.e. Basic Cost+All Taxes + Freight. The landed cost of last purchase order in the financial year	Rs./ Tonne	Annual	1) Purchase Order for basic rates and taxes 2) Freight document for rates	
2	Gross calorific value of NG	kcal/ SCM	Lot, Monthly, Yearly	1) Test report from Supplier 2) Test report from Government Accredited Lab 3) Standard Value as per Notification	
3	Annual NG quantity purchase	Million SCM	Lot, Daily, Monthly, Yearly	1) Purchase Order 2) Stores Receipt 3) SAP Entry in MM/PP/FI module 4) Annual Report	Gas Meter Reading, Bullet Pressure Reading



Sr No	Details	Unit	Frequency of record	Primary Documents from where the information can be sourced and to be kept ready for verification by Accredited Energy Auditor	Secondary Documents from where the information can be sourced and to be kept ready for verification by Accredited Energy Auditor
4	NG quantity consumed in power generation	Million SCM	Continuous, Daily, Monthly, Yearly	1) Daily Generation Report 2) Monthly Generation Report 3) GG Log Sheet 4) SAP Entry in MM/PP/FI module 5) Annual Report	Gas Meter Reading, Bullet Pressure Reading
5	NG quantity consumed in transportation	Million SCM	Daily, Monthly, Yearly	1) Vehicle Log book 2) Stores Receipt 3) Fuel Dispenser meter reading 3) Work Order for Internal Transportation	Gas Meter Reading, Bullet Pressure Reading
6	NG quantity consumed in process heating	Million SCM	Daily, Monthly, Yearly	1) DPR 2) MPR 3) Major Eqp Log Sheet 4) Product Mill Log Sheet 5) SAP Entry in MM/PP/FI module 6) Annual Report	Gas Meter Reading, Bullet Pressure Reading
<b>B</b>	<b>Liquefied Petroleum Gas (LPG)</b>				
1	Landed cost of Solid Fuel i.e. Basic Cost+All Taxes + Freight. The landed cost of last purchase order in the financial year	Rs./ Tonne	Annual	1) Purchase Order for basic rates and taxes 2) Freight document for rates	
2	Gross calorific value of LPG in kcal/kg.	kcal/ kg	Lot, Daily, Monthly, Yearly	1) Test report from Supplier 2) Test report from Government Accredited Lab 3) Standard Value as per Notification	
3	Annual LPG quantity purchase	Million kg	Lot, Daily, Monthly, Yearly	1) Purchase Order 2) Stores Receipt 3) SAP Entry in MM/PP/FI module 4) Annual Report	Gas Meter Reading, Bullet Pressure Reading
4	LPG quantity consumed in power generation	Million kg	Daily, Monthly, Yearly	1) DPR 2) MPR 3) GG Log Sheet 4) SAP Entry in MM/PP/FI module 5) Annual Report	Gas Meter Reading, Bullet Pressure Reading
5	LPG quantity consumed in process heating	Million kg	Daily, Monthly, Yearly	1) DPR 2) MPR 3) Major Eqp Log Sheet 4) Product Mill Log Sheet 5) SAP Entry in MM/PP/FI module 6) Annual Report	Gas Meter Reading, Bullet Pressure Reading



**Table 11: Documents for Quality Parameter**

Sr No	Details	Unit	Frequency of record	Primary Documents from where the information can be sourced and to be kept ready for verification by Accredited Energy Auditor	Secondary Documents from where the information can be sourced and to be kept ready for verification by Accredited Energy Auditor
<b>Quality Parameters</b>					
<b>A</b>	<b>Raw Material Quality</b>				
1	Raw Material Quality (Sector Specific Raw Material Quality testing)	%	Lot, Monthly	1) Internal Test Certificate 2) External Test Certificate from related Sector Govt Accredited Lab	1) Lab Test Report Register
<b>B</b>	<b>Coal Quality in CPP (As Fired Basis)</b>				
1	the Ash % in coal used in CPP/Cogen/WHRB	%	Lot, Daily, Monthly, Quarterly	1) Daily Internal Report from Lab on Fuel Proximate Analysis performed on each lot. 2) Test Certificate from Government Accredited lab. (Plant to maintain minimum 1 sample test in a quarter for Proximate and Ultimate Analysis i.e. 4 test certificates in a year for each fuel in case of CPP/Cogen/WHRB Fuel, for Process Fuel 1 sample test in a quarter for Proximate Analysis) 3) Purchase Order, where guaranteed GCV range is mentioned	1) Lab Register on Fuel Testing for Proximate Analysis 2) Calibration Record of instrument used for testing
2	the Moisture % in coal used in CPP/Cogen/WHRB				
3	the Hydrogen % in coal used in CPP/Cogen/WHRB				
4	the GCV value of coal used in CPP/Cogen/WHRB				





**Table 12: Documents related to Environmental Concern, Biomass/Alternate Fuel availability, Project Activities, New Line commissioning, Unforeseen Circumstances**

Sr No	Details	Unit	Requirement	Frequency of record	Primary Documents from where the information can be sourced and to be kept ready for verification by Accredited Energy Auditor	Secondary Documents from where the information can be sourced and to be kept ready for verification by Accredited Energy Auditor
<b>Miscellaneous Data</b>						
A	Additional Equipment installation after baseline year due to Environmental Concern					
(i)	Electrical Energy Consumption with list of additional Equipment installed due to Environmental Concern after baseline year in Sheet! Addl Eqp List-Env.	Lakh kWh	List of Equipment to be filled up	Daily, Monthly, Annual	Energy Meter Readings and Power consumption details of each additional equipment installed from 1st Apr to 31st March	1) EMS 2) Energy Meter 3) Addition Equipment List with capacity and running load 4) Purchase Order document 5) SAP Data in MM module
(ii)	Thermal Energy Consumption with list of additional Equipment installed due to Environmental Concern after baseline year in Sheet! Addl Eqp List-Env.	Million kcal	List of Equipment to be filled up	Daily, Monthly, Annual	Solid/Liquid/Gaseous Fuel consumption of each additional equipment installed from 1st Apr to 31st March	1) Fuel Flow Meter 2) Weigh Feeder 3) Purchase Order document 4) SAP Data in MM module
<b>B</b>	<b>Biomass/ Alternate Fuel availability</b>					
(i)	Details of replacement of Bio-mass with fossil fuel due to un-availability. This is required in fossil fuel tonnage in terms of equivalent GCV of Bio-mass (Used in Process)	Tonne	Fossil Fuel: Coal/ Lignite/Fuel Oil	Monthly	1) Authentic Document in relation to Bio-Mass/Alternate Solid Fuel/Alternate Liquid Fuel availability in the region. 2) Test Certificate of Bio-mass from Government Accredited Lab for GCV in Baseline and assessment year 3) Test Certificate of replaced Fossil Fuel GCV	



Sr No	Details	Unit	Requirement	Frequency of record	Primary Documents from where the information can be sourced and to be kept ready for verification by Accredited Energy Auditor	Secondary Documents from where the information can be sourced and to be kept ready for verification by Accredited Energy Auditor
(ii)	Details of replacement of Alternate Solid Fuel with fossil fuel due to un-availability. This is required in fossil fuel tonnage in terms of equivalent GCV of Alternate Solid Fuel (Used in Process)	Tonne		Monthly		
(iii)	Details of replacement of Alternate Liquid Fuel with fossil fuel due to un-availability. This is required in fossil fuel tonnage in terms of equivalent GCV of Alternate Liquid Fuel (Used in Process)	Tonne		Monthly		
<b>C</b>	<b>Project Activities (Construction Phase)</b>					
(i)	Electrical Energy Consumption with list of Project Activities and energy consumed during project activities treated as Construction phase in Lakh kwh Ref: Sheet!Project Activity List	Lakh kWH	List of Equipment to be filled up	Daily, Monthly	Energy Meter Readings of each project activity with list of equipment installed under each activity from 1st Apr to 31st March	1) EMS 2) Energy Meter 3) Addition Equipment List with capacity and running load 3) Purchase Order document 4) SAP Data in MM module
(ii)	Thermal Energy Consumption with list of Project Activities and energy consumed during project activities treated as Construction phase in Million kcal converted from different fuel Ref: Sheet!Project Activity List	Million kcal	List of Equipment to be filled up	Daily, Monthly	Solid/Liquid/Gaseous Fuel consumption of each project activity with list of equipment under each activity installed from 1st Apr to 31st March	1) Fuel Flow Meter 2) Weigh Feeder 3) Purchase Order document 4) SAP Data in MM module
<b>D</b>	<b>New Line/Unit Commissioning</b>					



Sr No	Details	Unit	Requirement	Frequency of record	Primary Documents from where the information can be sourced and to be kept ready for verification by Accredited Energy Auditor	Secondary Documents from where the information can be sourced and to be kept ready for verification by Accredited Energy Auditor
(i)	Electrical energy consumed in Lakh kWh during its commissioning till it attains 70% of the new line capacity utilisation	Lakh kWh		Daily, Monthly	1) Rated Capacity of new Process/line from OEM 2) Energy Meter Readings and Power Consumption record of process/line with list of equipment installed from 1st Apr to 31st March	1) EMS 2) Energy Meter 3) Addition Equipment List with capacity and running load
(ii)	Thermal energy consumed in Million kcal during its commissioning till it attains 70% of the new line capacity utilisation. The energy is calculated after converting from the different fuel GCV used in the new process/line	Million kcal		Daily, Monthly	1) Rated Capacity of new Process/line from OEM 2) Thermal Energy Consumption record with list of equipment from DPR/Log book/SAP Entry in PP module	1) Fuel Flow Meter 2) Weigh Feeder
(iii)	Final/Intermediary Product production during its commissioning up to 70% of new line/process capacity utilisation in Tonne	Tonne		Daily, Monthly	1) Rated Capacity of new Process/line from OEM 2) Production record from DPR/Log book/SAP Entry in PP module	1) Weigh Feeder
(iv)	Date of achieving 70% capacity utilisation of new process/line	Dates			1) Record/Document from SAP Entry/Log Book Entry/DPR/MPR	Operator's Shift Register
(v)	Electrical Energy consumed in Lakh kWh from external source during its commissioning till it attains 70% of the new unit capacity utilisation in Power generation	Lakh kWh		Daily, Monthly	1) Rated Capacity of new unit from OEM 2) Energy Meter Readings and Power Consumption record of unit from external source with list of equipment installed from 1st Apr to 31st March	1) EMS 2) Energy Meter 3) Addition Equipment List with capacity and running load



Sr No	Details	Unit	Requirement	Frequency of record	Primary Documents from where the information can be sourced and to be kept ready for verification by Accredited Energy Auditor	Secondary Documents from where the information can be sourced and to be kept ready for verification by Accredited Energy Auditor
(vi)	Thermal energy consumed in Million kcal during its commissioning till it attains 70% of the new unit capacity utilisation. The energy is calculated after converting from the different fuel GCV used in the new unit in Power generation	Million kcal		Daily, Monthly	1) Rated Capacity of new unit from OEM 2) Thermal Energy Consumption record with list of equipment from DPR/Log book/SAP Entry	1) Fuel Flow Meter 2) Weigh Feeder
(vii)	Net generation in Lakh kwh from the new unit in power generation, used in the Product Plant till the new unit achieved 70% of Capacity Utilisation	Lakh kWh		Daily, Monthly	1) Record/Document from SAP Entry/Log Book Entry/DPR/MPR	1) EMS 2) Energy Meter
(viii)	Date of achieving 70% capacity utilisation of new unit in Power generation	Dates			1) Record/Document from SAP Entry/Log Book Entry/DPR/MPR	
<b>E</b>	<b>Unforeseen Circumstances</b>					
(i)	Electrical Energy Consumption with list of unforeseen circumstances consumed in Lakh kWh claimed for Normalisation	Lakh kWh	Unforeseen Circumstances: Situation not under direct or indirect control of plant management		1) Relevant document on Unforeseen Circumstances beyond the control of plant 2) Energy Meter Readings and Power Consumption during the said period of unforeseen circumstances	1) EMS 2) Energy Meter 3) Addition Equipment List with capacity and running load
(ii)	Thermal Energy Consumption with list of unforeseen circumstances consumed in Million kcal claimed for Normalisation	Million kcal			1) Relevant document on Unforeseen Circumstances beyond the control of plant 2) Thermal Energy Consumption record during the said period of unforeseen circumstances from DPR/Log book/SAP Entry	1) Fuel Flow Meter 2) Weigh Feeder



**Table 13: Documents related to External Factor**

Sr No	Details
<b>Document related to external factor</b>	
(i)	<b>Market Demand</b>
	1)Product Storage Full record from Product Mill Log book 2)SAP entry in SD and FI module 3) SAP entry in PP module 4) Document related to sales impact of market
(ii)	<b>Grid Failure</b>
	1) SLDC Reference No. for planned Stoppages from respective Substation 2) Log book record of Main Electrical Substation of Plant 3) DPR 4) MPR 5) SAP entry in PM module of Electrical department
(iii)	<b>Raw Material un-availability</b>
	1) Material Order copy and denial document from Mines owner 2) SAP entry in MM/FI module on raw material order 3) DPR 4) MPR
(iv)	<b>Natural Disaster</b>
	1) Supporting Authentic document from Local district Administration 2) Major Eqp Log Sheet 3) Major Eqp operators Report book 4) DPR 5) MPR
(v)	<b>Major change in government policy hampering plant’s process system</b>
	1)Government Notification or Statutory order 2) Authentic document from plant on effect of Major Eqp production due to policy change 3) DPR 4) MPR 5) SAP Entry on production change
(vi)	<b>Unforeseen circumstances/Labour Strike/Lockouts/Social Unrest/Riots</b>
	1) Relevant document on Unforeseen Circumstances beyond the control of plant 2) Energy Meter Readings and Power Consumption during the said period of unforeseen circumstances 3) Thermal Energy Consumption record during the said period of unforeseen circumstances from DPR/Log book/SAP Entry
<b>B</b>	<b>Note</b>
(i)	The hard copy/Printouts is to be signed by Authorised signatory, if SAP data is used as documents

## 5. Understanding Conditions

“Normalisation” means a process of rationalization of Energy and Production data of Designated Consumer to take into account changes in quantifiable terms that impact energy performance under equivalent conditions.

There are several factors that need to be taken into consideration in the assessment year such as change in product mix, capacity utilization, change in fuel quality, import/export of power etc **influenced by externalities i.e., factors beyond the control of Plant**, while assessing

the Specific Energy Consumption (SEC) of the plant.

In order to incorporate and address the changes happening in the DCs from Baseline Year to Assessment year, Bureau has formulated Sub-Technical Committees under the Technical Committee for each sector. The sub-Technical committees include representatives from DCs, research associations, Concerned Ministries, expert bodies from government and private sector etc. The Sub-committee identified and prepared the normalization factors with consensus from the DCs.



The operating parameters in the Assessment year have to be normalized w.r.t Baseline year so as to avoid any favorable or adverse impact on the specific energy consumption of the plant. This will also assist in quantifying and establishing the benefits of the energy efficiency projects implemented by the plant

### 5.1. Specific Issues

88. The complete Normalisation Process with equations and calculations have been dealt separately in sector specific Normalisation documents. EmAEA needs to study the document to carry out the verification process.
89. The details of data furnished in Form 1 shall be drawn from the sector-specific Pro-forma, referred to in the guidelines, relevant to every designated consumer and the said sector-specific Pro-forma, duly filled in, shall also be annexed to Form 1
90. The Sector Specific Pro-forma have built-in calculations of Normalisation with specific Energy Calculation in the summary sheet. The notified Form 1 will be generated automatically from the Pro-forma, once filled in all respect.
91. The normalization will be given to DCs only upon submission of valid/authentic supporting documents. Failing which, the DC will not be eligible for normalizations.
92. The operating parameters for which normalization has been provided but not being claimed, the DC should submit the valid reason for the same.
93. For the new DCs, which are not covered under PAT scheme shall also fill up the Sector Specific Pro-forma for the verification of their total energy consumption.
94. Notional/Normalized Energy will not to be considered in Total Energy Consumption,

while deciding whether a plant falls under the designated consumer category or not. Normalization energy is considered only in the calculation of Gate to Gate Specific Energy Consumption.

95. **External factors definition:** The factors over which an individual DC does not have any control but that can impact the SEC are classified as uncontrollable factors.
  - i. External Factors should be scrutinized carefully for Normalisation applicability
  - ii. The defined external factors in the document are to be supported by external authentic documentary evidences
  - iii. Any other undefined external factor, which may affect production or energy of a DC should be brought in the Verification Report by EmAEA with authentic documentary evidences
  - iv. The external factors identified are as follows:
    - a. Market Demand
    - b. Grid Failure/Breakdown (Grid not Synchronized with CPP)
    - c. Raw Material Unavailability
    - d. Natural Disaster (Flood, Earthquake etc)
    - e. Major change in Government policy (affect plant's process system)
    - f. Unforeseen Circumstances (Labour Strike/Lockouts/Social Unrest/Riots/Others etc)
96. **Boundary Limit:**
  - a. Establishment of plant GtG boundary is required with clear understanding of raw material input, Energy input, Power Import/Export, Intermediary



- product Import/Export, Colony Power, Construction/Others Power, Power supplied to other Ancillary unit outside the plant boundary
- b. Inclusion and exclusion from the plant boundary is maintained as established in the baseline year
- c. Section wise Screen shot of SCADA from CCR/DCS is to be included in the verification report
- d. Raw material input in the Plant boundary to be recorded for inclusion in the verification report

## 5.2. Fuel

### 97. Fuel Testing

- a. Validation of Fuel quality testing from external and internal lab for same sample for each solid fuel used
- b. Test Certificate from Government Accredited Lab (NABL):
  - i. **CPP Fuel:** Plant to maintain minimum 1 sample test certificate in a quarter for Proximate and Ultimate Analysis i.e. 4 test certificates in a year for each fuel
  - ii. **Process Fuel:** 1 sample test certificate in a quarter for Proximate Analysis i.e. 4 test certificates in a year for each fuel
- c. Liquid /Gaseous Fuel Testing: As per Table 9
- d. Reproducibility Limit of same sample
  - i. The means of the result of duplicate determinations carried out in each of two laboratories on representative portions taken from the same sample at the last stage of sample preparation, should not differ by more than 71.7 kcal/kg as per ISO 1928: 1995 (E)

- ii. If the difference is greater than 71.7 kcal/kg, the difference will be added to the GCV value of the test result obtained in DC's Lab for that particular quarter
- e. Daily Proximate analysis record of all types of Coal to be maintained at Lab for ongoing submission as document related to fuel analysis

### 98. Note on Proximate and Ultimate Analysis of Coal

If the ultimate analysis has not been carried out in the baseline year for getting H% result, following conversion formulae from Proximate to Ultimate analysis of coal could be used for getting elemental chemical constituents like %H.

### Relationship between Ultimate and Proximate analysis

$$\begin{aligned} \%C &= 0.97C + 0.7(VM + 0.1A) - M(0.6 - 0.01M) \\ \%H &= 0.036C + 0.086(VM - 0.1xA) - 0.0035M^2(1 - 0.02M) \\ \%N &= 2.10 - 0.020 VM \end{aligned}$$

Where  
 C = % of fixed carbon  
 A = % of ash  
 VM = % of volatile matter  
 M = % of moisture

- 99. The basis of Fuel sample testing i.e., As Received Basis (ARB), As Fired Basis (AFB), As Dried Basis (ADB) for calculating or measuring GCV in assessment year will be same as made during baseline year. However, the location of Fuel sample testing and weight measurement should remain identical. This will be identified in the Pro-forma under Remarks column, if the basis is other than As Fired.
- 100. The status quo to be maintained in the assessment year for the basis of measuring GCV of Fuel (For Ex. As Received Basis, As Fired Basis, As Dried Basis etc.) as



followed in the baseline year i.e., if DC has submitted GCV value on “as received basis”, the basis will be same in the assessment year as well. The DC has to write in the remarks/source of data field on basis of GCV taken in the assessment year. However, the EmAEA is requested to report the Fuel GCV “As fired basis” in the verification report, which may become baseline for subsequent PAT cycles.

101. Standard applicable IS Norms should be followed for Fuel (Solid, Liquid, Gas) sampling for internal or external lab from different location

102. Internal Coal Testing method to be elaborated as per IS Norms and to be included as document in the EmAEA report.

103. Gross Calorific Value or High Heat Value:

a. It is advised to measure the GCV of coal with the help of Bomb Calorimeter only in the assessment year and record the value daily in the LAB register for ongoing submission as document related to Fuel analysis.

b. The calculation method for calculating GCV/NCV from Proximate and Ultimate Analysis in the assessment year will remain same as made during baseline year.

c. In the absence of formulae for calculating GCV, the following Dulong’s formulae may be used for Gross Calorific Value (GCV) or High Heat Value (HHV) calculation

Dulong’s Formulae (Value from Ultimate Analysis) for GCV covers basic principle, that there are only 3 components in a fuel which generate heat i.e., Carbon, Hydrogen and Sulphur as per following expression

$$Q = 81 \times C + 342.5 \times [H - O/8] + 22.5 \times S$$

Where

Q is GCV in kcal/kg

C = % of Carbon by weight

H=% of Hydrogen by weight

O=% of Oxygen by weight

S=% of Sulphur by weight

104. Net Calorific Value (NCV) or Low Heat Value (LHV):

a. The NCV includes the Steam-condensing latent heat, the NCV is defined as the gross calorific value minus the latent heat of condensation of water (at the initial temperature of the fuel), formed by the combustion of hydrogen in the fuel. The latent heat of steam at ordinary temperature may be taken as 587kcal/kg. The NCV could be calculated by the following expression

$$NCV = GCV - 5.87 \times (9 \times H + M)$$

Where

NCV = Net Calorific Value (kcal/kg)

GCV = Gross Calorific Value (kcal/kg)

H= % of Hydrogen by weight

M= % of Moisture by weight

### 5.3. Normalization Condition and calculation

105. Plant should maintain the records of the number of outages during the baseline and assessment year.

106. Plant needs to maintain proper Energy Meter Reading/Records due to external factors for baseline as well as for assessment year.

107. Section wise Energy metering (Electrical and Thermal) is required for making Equivalent Product in Textile sub-sectors. Proper calculation document should be maintained, if energy figures are arrived by calculation method.





108. Plant to maintain Frequency of calibration and records of Energy monitoring equipment.
109. Calibration records of all weighing and measurement system with frequency of calibration to be included in the verification report.
110. The documents maintained by DCs should clearly show the direct reasons of the shutdown along with time and duration in hours and Energy consumed with quantity of Feed to reach the pre-shutdown production level for each such break-down or shutdown.
111. Additional Nos of Equipment details in Pro-forma:
  - a. Additional Product/Section detail: The Designated Consumer may furnish additional Product/Section details as per sectional format in a separate Excel Sheet for insertion in the existing Pro-forma if sectional input data format is full. Otherwise, Total energy of additional section or product could be converted into the last product or section through SEC of both the product/section and feed the same in the last product/section format for baseline as well as for assessment year.
  - b. Additional Line for Start/Stop Normalization: If the nos of line/unit exceeds from the existing nos, the DCs are advised to insert separate excel sheet of same format for finalization and insertion of additional line with normalization calculation by BEE.
  - c. Additional Boiler detail (Process/ Cogen): Additional Nos of Process or Co-gen boiler will be annexed in a separate Excel sheet as per the format provided in the Pro-forma for Boilers.
112. Lump CPPs: Information for all parameters of CPP <sup>12</sup> to be provided for all CPPs in Weighted Average terms w.r.t Gross Unit Generation in the CPP section, except for Design Heat Rate DHR (1,2,...)= $DHR1 \times C1 + DHR2 \times C2 + \dots / (C1 + C2 + \dots)$ .
113. Lump Co-Gen (Extraction cum Condensing): The total nos of Co-Gen should be treated as lump power source and accordingly details to be filled in the Pro-forma as per following example in Table No #14 separately for Extraction cum Condensing Turbine
114. Lump Co-Gen (Back Pressure): The total nos of Co-Gen should be treated as lump power source and accordingly details to be filled in the Pro-forma as per following example in Table No #14 separately for Back Pressure Turbine.

**Table 14: Lump Co-Generation treatment**

Sr No	Description	Formulae	Unit	Remarks
(i)	Install Capacity (C1.....Cn) <sup>13</sup>	$C1 + C2 + \dots + Cn$	MW	Sum of capacity
(ii)	Annual Gross Unit generation (AGG1...AGGn)	$AGG1 + AGG2 + \dots + AGGn$	Lakh kWh	Sum of Generation
(iii)	Auxiliary Power Consumption (APC1.... APCn)	$APC1 + APC2 + \dots + APCn$	Lakh kWh	Sum of APC
(iv)	Design Heat Rate	$DHR (1,2,...n) = \frac{DHR1 \times C1 + DHR2 \times C2 + \dots}{(C1 + C2 + \dots + Cn)}$	kcal/ kWh	Weighted Average of Design Heat Rate w.r.t to Installed Capacity

<sup>12</sup> CPP: Steam Turbine Generator (STG)/ Gas Turbine (GT)/Gas Generator(GG)/Diesel Generator (DG)

<sup>13</sup> 1,2,3.....n: No of Cogen Sources



Sr No	Description	Formulae	Unit	Remarks
(v)	Running Hours	$(RH1 \times AGG1 + RH2 \times AGG2 + \dots + RHn \times AGGn) / (AGG1 + AGG2 + \dots + AGGn)$	Hrs	Weighted Average of Running Hours w.r.t to Annual Generation
(vi)	Auxiliary Power Consumption	$(ii) \times 100 / (iii)$	%	APC%
(vii)	Total Thermal energy used in Process	$TEPr1 + TEPr2 + \dots + TEPrn$	Million kcal	Sum of Total Thermal Energy used in Process
(viii)	Total Thermal energy used in Power	$TEPo1 + TEPo2 + \dots + TEPon$	Million kcal	Sum of Total Thermal Energy used in Power
(ix)	Heat Rate of Co-Gen	$HR1 \times AGG1 + \dots + HRn \times AGGn / (AGG1 + \dots + AGGn)$	kcal/kwh	Weighted Average of Heat Rate

115. In case a DC commissions a new line/ production unit before or during the assessment/target year, the production and energy consumption of new unit will be considered in the total plant energy consumption and production volumes once the Capacity Utilisation of that line has touched / increased over 70%. However, the energy consumption and production volume will not be included till it attains 70% of Capacity Utilisation. Energy consumed and production made (if any) during any project activity during the assessment year, needs to be exclusively monitored and will be subtracted from the total energy and production in the Assessment year. Similarly, the same methodology will be applied on a new unit installation for power generation (CPP) within the plant boundary.

The Capacity Utilisation will be evaluated based on the OEM document on Rated Capacity or Name plate rating on capacity of New Line/ Production Unit and the production of that line/unit as per DPR/ Log sheet.

#### 5.4. Normalisation General Issue

116. Normalisation Environmental Concern: Any additional equipment installed to comply with the Environmental standards

as applicable in the baseline, will not qualify for this Normalization i.e., If any Plant after the baseline year has deviated from the Environmental Standards imposed in the baseline year and additional equipment have been installed after the baseline year to comply with these Standards, the plant is not eligible for Normalization.

117. Unavailability of biomass/Alternate fuel in assessment year as compared to the baseline year due to external factor. The normalization for Unavailability for Biomass or Alternate Fuel takes place only if sufficient evidence in-terms of authentic document is produced. Plant to furnish the data replacement of fossil fuel from Biomass/ Alternate Fuel (Solid/Liquid) in the assessment year w.r.t. baseline year. The energy contained by the fossil fuel replacement will be deducted in the assessment year

118. If a captive power plant or cogeneration plant caters to two or more DCs for the electricity and/or steam requirements. In such scenario, each DC shall consider such captive power plant or cogeneration plant in its boundary and energy consumed by such captive power plant or cogeneration plant shall be included in the total energy consumption. However, electricity in terms of calorific value (as per actual heat



rate) and steam in terms of calorific value (as per steam enthalpy) exported to other plants shall be subtracted from the total energy consumption.

119. Normalisation for Start Stop: The Designated Consumer has to furnish the Electrical and Thermal Energy Consumption by taking into account the saleable or intermediate production made during Hot-Cold Stop and Cold-Hot Start.
  - a. Hot to Cold Stop: The Plant ceases to halt after abrupt tripping of main equipment due to external factor.
  - b. Cold to Hot Start: The Plant is restarted after a brief halt/stoppages to reach the normal production
120. For the Start/Stop Normalization following factor may be considered:
  - a. At the time of Hot to Cold stop, due to external factors, electric energy consumed in the major section/plant to maintain essential loads of the plant shall be deducted from the total energy consumption.
  - b. At the time of Cold to Hot start after Hot to Cold stop due to external factors, specific energy consumption of the major section/major equipment shall be multiplied with the actual production during this time and added to the total energy consumption.
  - c. The actual equivalent production shall also be added to the total production.
121. For Normalization factors, which became applicable due to external factors, authentic documents to be produced by DC for the baseline as well for the assessment year. In absence of these authentic documents, no Normalization Factor will be applied/ Considered.
122. For Investment for year 2010-11,2012-13, 2013-14 and 2014-15 will be included in the assessment year of sector specific pro-forma
123. Any factor, which has not been considered in the document and Form 1, the Empanelled Accredited Energy Auditor will report it separately with possible solution for the same and Annexed to the Form B (Verification Form)
124. Sector specific Pro-forma, Normalization document and aforementioned guidelines are the major elements of the M&V process, and additional Sector Specific M&V guidelines are provided in Annexure I-VIII.
125. Some of the information sought under this annexure could be considered as supporting information/documents, which may help EmAEA in submitting the Form B.



## 6. Abbreviations

NAPCC	National Action Plan for Climate Change
NMEEE	National Mission on Enhanced Energy Efficiency
PAT	Perform Achieve and Trade
M&V	Monitoring and Verification
MoP	Ministry of Power
BEE	Bureau of Energy Efficiency
SDA	State Designated Agency
EOC	End Of PAT Cycle
DCs	Designated Consumer
EmAEA	Empanelled Accredited Energy Auditor Firm
SEC	Specific Energy Consumption
Pro-forma	Sector Specific Pro-forma for Form 1
ECM	Energy Conservation Measures
GtG	Gate- to- Gate
PAD	Performance Assessment Document
ESCerts	Energy Saving Certificates
AEA	Accredited Energy Auditor
CPP	Captive Power Plant
AY	Assessment Year
BY	Baseline Year
DCS	Distributed Control System
CCR	Central Control Room
SCADA	Supervisory Control and Data Acquisition
SAP	System Application and Product Software
DPR	Daily Production Report
MPR	Monthly Production Report
DGR	Daily Generation Report
MGR	Monthly Generation Report
IEX	Indian Energy Exchange
PXIL	Power Exchange of India Limited
OEM	Original Equipment Manufacturer
GCV	Gross Calorific Value
NCV	Net Calorific Value
NABL	National Accreditation Board for Testing and Calibration Laboratories
TPP	Thermal Power Plant



## **7. Annexure**

- (i) Annexure I: Thermal Power Station
- (ii) Annexure II: Steel
- (iii) Annexure III: Cement
- (iv) Annexure IV: Fertilizer
- (v) Annexure V: Aluminium
- (vi) Annexure VI: Pulp & Paper
- (vii) Annexure VII: Textile
- (viii) Annexure VIII: Chlor-Alkali



## 7.1. Annexure I: Thermal Power Station

### 1. Auxiliary Power Consumption (APC)

EmAEA may verify the section/ equipment wise motor ratings. The sections/ equipment shall include

**Table 15: Auxiliary Power Consumption Details (a,b,c)**

#### a. Boiler and Auxiliaries

S. No.	Equipment	Power Rating (kW)	Current Rating (Amperes)
1.	Coal Grinding Mills		
2.	Coal Feeders		
3.	Boiler Re-Circulation Pump		
4.	Primary Air(PA) Fans		
5.	Secondary Air(SA) Fans		
6.	Induced Draught (ID) Fans		
7.	Seal Air fans		
8.	Scanner air fans		
9.	Air Pre-Heater (APH)		
10.	Miscellaneous/ Missed out equipment		

#### b. Turbine and auxiliaries

S.No.	Equipment	Power Rating (kW)	Current Rating (Amperes)
1.	Condensate Extraction Pump (CEP)		
2.	Boiler Feed Pump (BFP)		
3.	Boiler Feed-booster Pump (BFBP)		
4.	Closed Circuit Cooling Water (CCCW) Pump/ De-Mineralised Cooling Water (DMCW) Pump		
5.	Auxiliary Cooling Water (ACW) Pumps		
6.	Condensate Polishing Unit (CPU)		
7.	Lube Oil Pumps		
8.	Seal Oil Pumps		
9.	Stator Water Cooling Pumps		
10.	Miscellaneous equipment		



**c. Balance of Plant**

S.No.	Equipment	Power Rating (kW)	Current Rating (Amperes)
1.	Compressed Air System		
a)	Instrument Air Compressor		
b)	Service Air Compressors		
2.	Cooling Water (CW) Pumps		
3.	Cooling Tower (CT) Fans		
4.	Water Treatment Plant (WTP)		
a)	Clarifiers		
b)	Filters		
c)	Pumps		
d)	Ion Exchangers		
e)	Miscellaneous/ Missed out equipment		
5.	Coal Handling Plant		
a)	Wagon Unloading System		
b)	Crushers		
c)	Belts Conveyors		
d)	Stacker Reclaimer		
e)	Miscellaneous/ Missed out equipment		
6.	Ash handling System		
a)	Pumps		
b)	Dry Ash Handling System		
c)	Wet Ash Handling System		
d)	Miscellaneous/ Missed out equipment		
7.	Fire Fighting System		
8.	Air Conditioning System		
9.	Lighting		
10.	Transmission System		
11.	Miscellaneous equipment		

This data shall be produced by the DCs for verification of section wise APC. If any item has been missed out in the table above, it shall be inserted by the DC.

The DC shall submit all design documents, manufacturers data sheet, etc. in support of the equipment ratings if required.

**2. Coal Handling Plant**

**a. Coal Input**

The DC shall submit a copy of Fuel Supply Agreement (FSA) in which the coal quality shall appear. Also, the DC shall submit the transportation agreement/ contract indicating the amount and quality of coal procured.



- b. Scheme  
A schematic representation of the coal handling plant shall be provided by the DC indicating the flow of coal from wagons to boilers. The description shall include hours of operation and number of equipment in running and standby condition.
  - c. Coal Quality  
The ultimate and proximate analysis of coal shall be submitted by the DC. The coal sample shall be taken at coal unloading, stacking and bunker feeding. The lab report in this regard shall be accepted.
3. Heat Rate  
The DC shall give the fully traceable calculation for turbine Heat Rate, Gross Heat Rate and Net Heat Rate. The values taken for heat rate calculation shall be backed by evidences, which can be screen shot of DCS for the particular parameter.
  4. Parameter verification  
The DCs shall make the log books and Daily Generation Report (DGR) available as and when needed.
  5. Fuel Oil  
The DCs shall submit the liquid oil supply contract mentioning the properties of oil. Also, the consumption shall be backed by calculation and pictures/ screen shot of level indicators/ flow counter, etc.
6. Balance diagrams
    - a. The DCs shall submit the Heat Mass Balance Diagrams showing the complete cycle.
    - b. Water Balance Diagram shall also be submitted.
  7. Fuel Mix Normalisation in Gas based Thermal Power Plant  
Due to change in fuel mix i.e., % of consumption of Gas and Oil/other fuel in the assessment year w.r.t. baseline year, the variation in Boiler efficiency is evident. The same needs to be normalized as per total generation from Gas and Oil/other fuel and design boiler efficiency at 100% for gas and Oil/other fuel.
  8. General
    - a. The scheme/ layout diagram of all sub-systems, e.g., CHP, AHP, WTP, etc. shall be submitted by the DCs. This shall facilitate in identifying the boundary condition of systems/ plant.
    - b. The DCs shall submit the maintenance history of systems/ equipment.
  9. Plant Boundary
    - a. The plant boundary shall consist of the BTG island, Water Treatment plant (WTP), Effluent Treatment Plant (ETP), Coal Handling Plant (CHP), Ash Handling Plant, CW System, Compressed Air System, Fire Fighting system, Transmission System, etc. A typical sample of Plant boundary condition is represented below





Figure 8: Ex-GtG Boundary for Thermal Power Plant

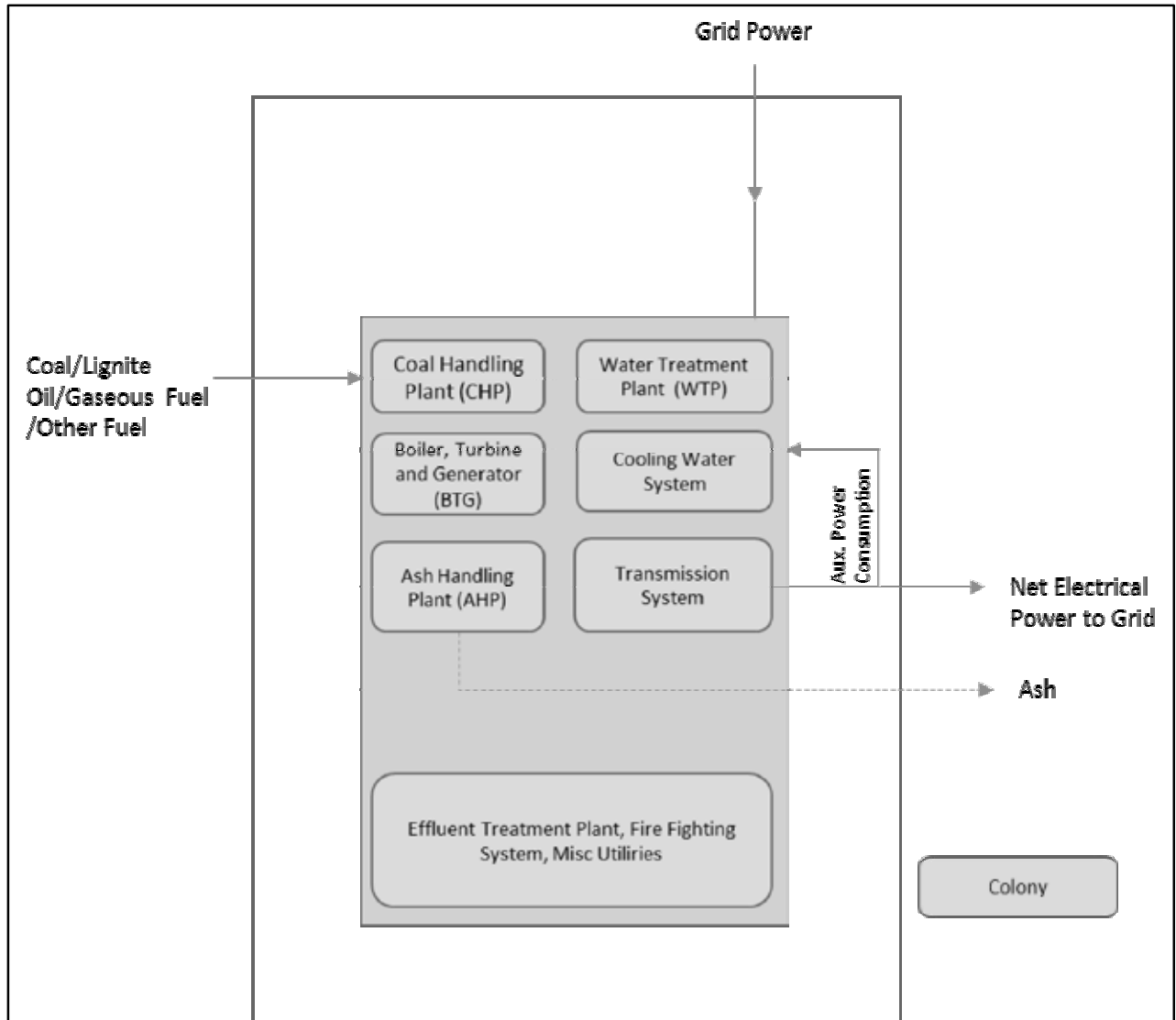

The colony does not form a part of the plant boundary and hence it is kept outside. In the figure above. The DC shall submit a latest Plot Plan of the station indicating all the systems/sub-systems.

b. The station energy balance diagram to be included in the Verification report. A typical sample of the diagram is shown below for Coal/Lignite/Oil/Gas based Power Plant and Combined Cycle Gas Turbine



Figure 9: Ex-Coal/Lignite/Oil/Gas based Thermal Power Plant Energy balance diagram

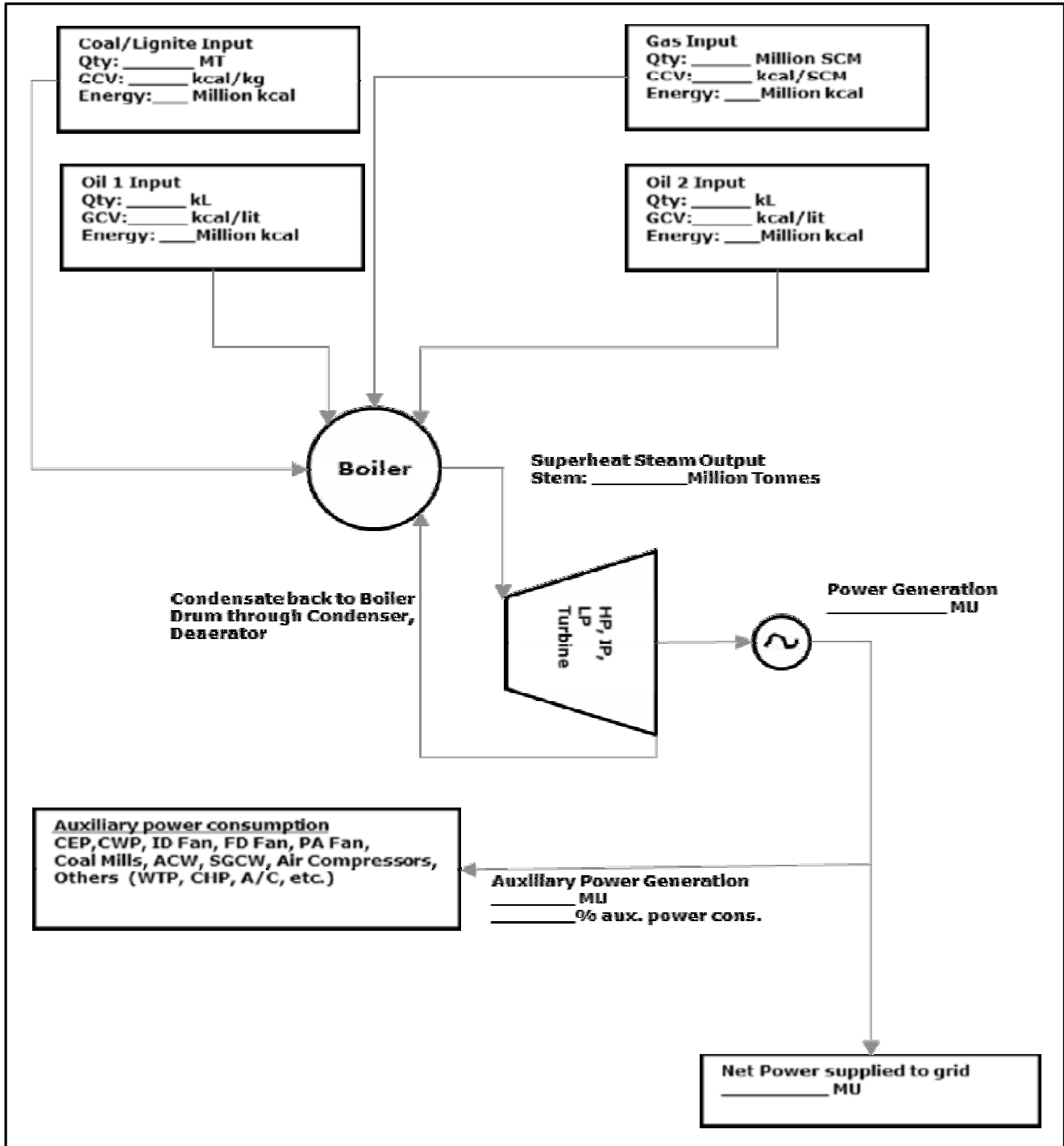
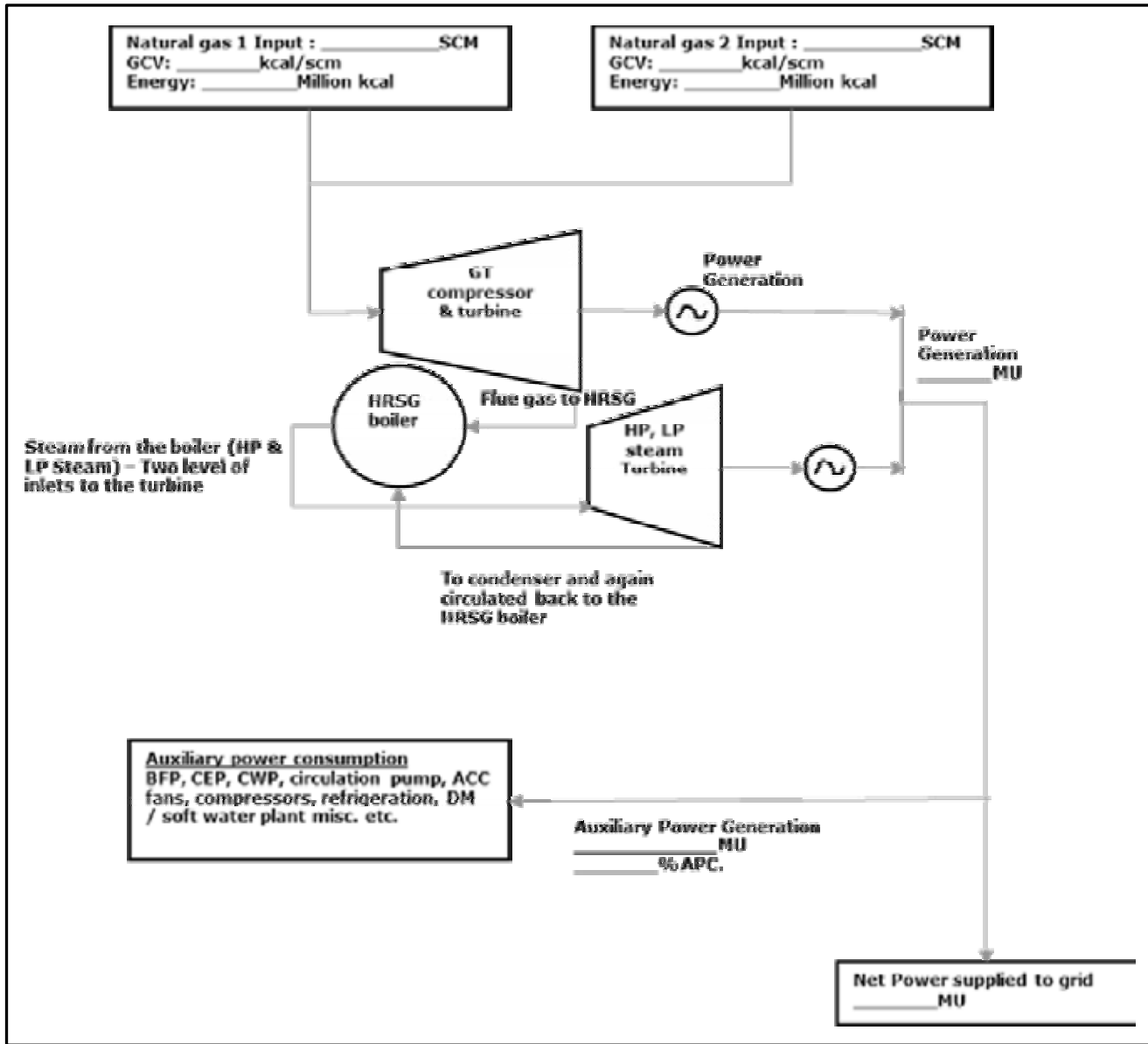



Figure 10: Ex-CCGT Energy balance diagram



## 7.2. Annexure II: Steel

### A: Integrated Steel Plant

1. The data submitted for verification and other figure for SEC calculation of any unit has to be in line with the units declared production and consumption figures as per the statutory financial audit and declaration in their annual report.
2. EmAEA, while verifying the SEC calculation should also cross verify the input figures based on the procurement plans and physical receipts.
3. The transit and handling losses have to be within the standard norms allowable under financial audit.
4. Crude steel is the product output of an Integrated Steel Plant (ISP). The term is internationally used to mean the 1st solid steel product upon solidification of liquid steel. In other words, it includes Ingots (in conventional



mills) and Semis (in modern mills with continuous casting facility). In PAT Scheme, for ISP, Crude steel is considered as the major product output.

5. The energy impact of any basic input such as Pellet, Sinter, DRI, Oxygen, Nitrogen, Argon, which has been either imported and/ or discontinued during assessment or baseline years, the upstream/notional energy impacts have to be apportioned in SEC as the case may be.
6. Import of any finished or semi-finished fuel input say coking coal vs coke, which has been either imported and/ or discontinued during assessment or baseline years, the upstream/notional energy impacts have to be apportioned in SEC as the case may be
7. For verification process, the DC shall provide all necessary information, supporting documents and access to the Plant site to EmAEA. It will be the responsibility of the EmAEA to maintain the confidentiality of the data collected and not to use for any other purpose except for the PAT scheme.
8. Quality of raw material for the purpose of normalisation needs to

be maintained as per the frequency of monitoring of the particular raw material and has to be maintained and submit to EmAEA by the plant, duly signed by the authorized signatory of the Designated Consumer.

9. In case of normalisation benefit, unit has to provide metering and measurement of energy inputs for all the energy parameters, for which normalisation is claimed.
10. All the energy input calorific values for purchased energy and inputs that impact energy performance of unit shall be submitted based on suppliers documented analysis and contractually agreed and signed documents by competent authority. All these documents are mandatory to be counter signed by auditor. A third party determination of calorific Value of each fuel used in plant to be submitted for each quarter carried out by Government Accredited Laboratory (NABL).

### B: Sponge Iron Sub-Sector

11. The entire sub-sector is divided into 7 group on similarity of product
12. The major product in 7 group is as per table below

**Table 16: Sponge Iron Subsector- Major Product details**

Sr No	Sub-Sector Group	Major Product	Remarks
1	Sponge Iron	Sponge Iron	
2	Sponge Iron with Steel Melting Shop	Sponge Iron	
3	Sponge Iron with Steel Melting Shop and Others (Ferro Chrome, FeMn, SiMn, Pig Iron, Ferro Silicon, Rolling Mills etc)	Sponge Iron	
4	Ferro Alloy	SiMn	
5	Ferro Chrome	Ferro Chrome	
6	Mini Blast Furnace (MBF)	Pig Iron	
7	Steel Processing Unit (SPU)	Steel	



13. The Energy consumption of Pellet Plant shall not be included in the assessment year as well as in the baseline year. The calculation for the same is included in the summary sheet of Pro-forma.
14. For Inclusion of Pellet Plant in GtG Specific Energy Consumption, The DC needs to specify the same so that the Summary sheet needs to be modified.
15. The Electrical and Thermal energy of Pellet Plant should be verified through proper measurement and Energy meters
16. Calibration records of all weighing and measurement system with frequency of calibration to be included in the verification report
17. Section wise SCADA Screen shot if required to be included in the verification report by EmAEA
18. The Energy and Mass balance calculation is required to be included in the verification report.
19. Section wise energy consumption needs to be recorded and included in the verification report.
20. The equivalent product is calculated based on the Product Mix calculation in the pro-forma. A typical process flow along with the location of major product is shown in the diagram. The same shall be included in the verification report for different section of Sponge Iron sub-sector.

Figure 11: Product Mix diagram

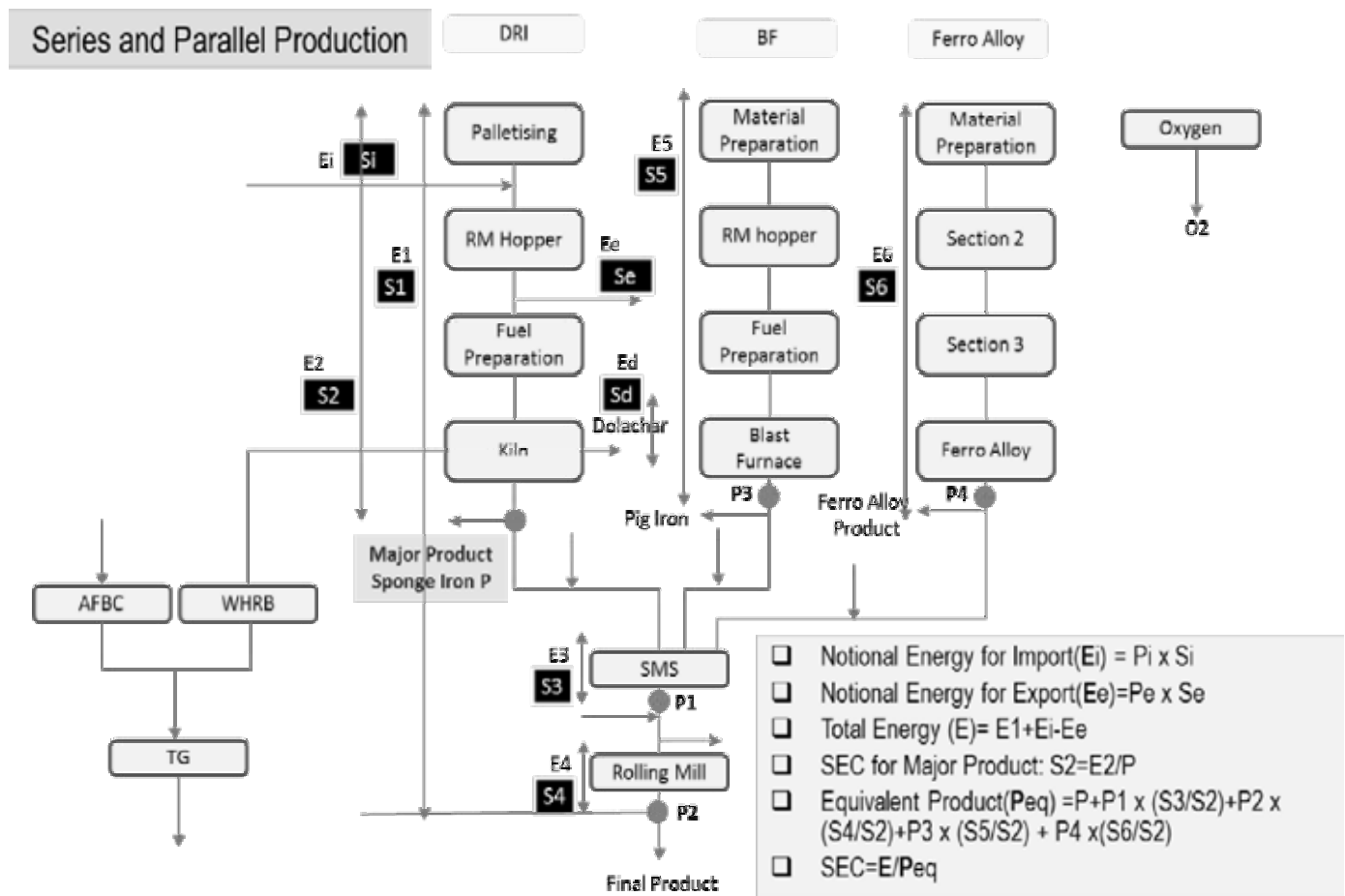



21. Demarcation of plant boundary is required with clear understanding of raw material input, Energy input, Power Import/Export, Intermediary product Import/Export, Colony Power, Construction/Others Power, Power supplied to other Ancillary unit outside the plant boundary. A typical sample of Plant boundary condition is represented below

Figure 12: Ex-GtG Boundary boundary for Sponge Iron Sub-sector

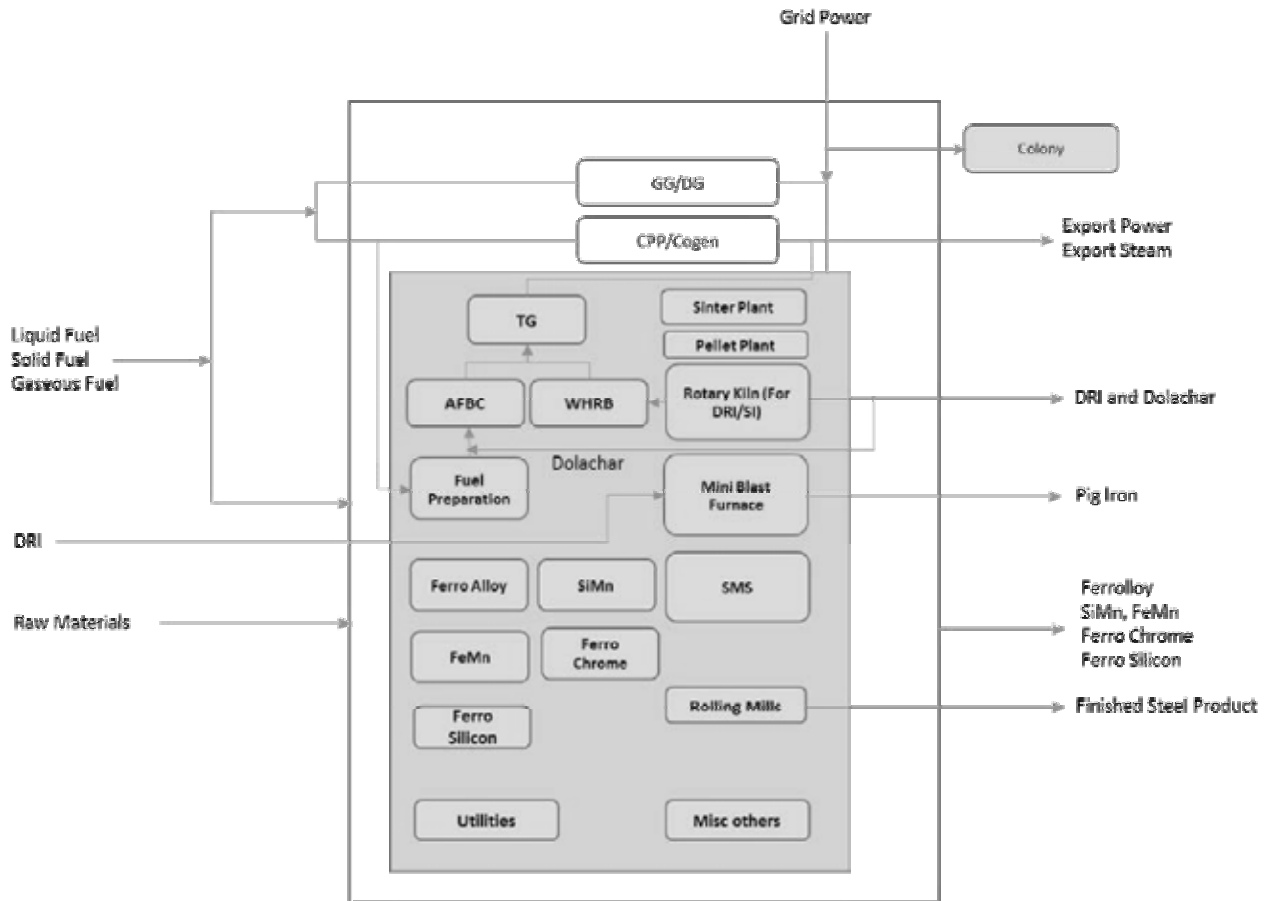

### 7.3. Annexure III: Cement

1. Preservation Power for Stopped Kiln: For kiln which goes under stoppages due to external factors, a certain quantity of power is required for safety and certain operations which needs to be maintained. The normalization for this power will be considered provided the DC has the baseline and assessment year data. This difference of preservation power in the baseline as well as the assessment year shall be subtracted from the total energy consumed.
2. Frequency of Lab Analysis from NABL accredited Laboratories for providing normalization for Raw material Quality in the subsequent cycles:
  - 2.1. Burnability analysis for raw mix – Once in each quarter
  - 2.2. Limestone Bond index – Once in a year
3. Normalisation due to Non availability of fly ash due to external factor: DC to submit support of claim on unavailability of fly ash during Assessment year to the EmAEA with sufficient data and documentation.



EmAEA to establish the facts whether in the vicinity of the particular DC, other Plants/DCs are getting Fly ash or not.

documentation to be provided by DC as per the instructions given in Cement sector Pro-forma.

4. The status quo to be maintained in the assessment year for the basis of measuring GCV of Fuel (For Ex. As Received Basis, As Fired Basis, As Dried Basis etc.) as followed in the baseline year i.e., if DC has submitted GCV value on “as received basis”, the basis will be same in the assessment year as well. The DC has to write in the remarks/source of data field on basis of GCV taken in the assessment year. However, The EmAEA is requested to report the Fuel GCV “As fired basis” in the verification report, which may become baseline for subsequent PAT cycles.
5. Plant Stoppages and Start due to high Clinker stock or Silo Full to be considered as external factor: Necessary
6. Normalisation on Use of Wet Fly Ash due to non-availability of dry Fly Ash: DC has to submit proper authentic documents to establish the increase in energy during AY due to usage of wet fly ash due to external reason. EmAEA to establish the facts whether in the vicinity of the particular DC, other Plants/DCs are getting dry Fly ash or not
7. Some of the information sought under this annexure could be considered as supporting information/documents, which may help EmAEA in submitting the Form B.
8. Review of Section wise specific power consumption (Line wise)

**Table 17: Section wise Specific Power Consumption Details**

Sr No	Section	kWh/tonne of Material	Conversion Factor to Clinker	kWh/tonne of Clinker	kWh/tonne of Cement	Remarks
1	Crusher					
2	Raw Mill					
3	Kiln					
4	Coal/Petcoke Mill					
5	Cement Mill					
6	Packing					
7	Utilities					
8	Misc					
	<b>Sum</b>					

9. Demarcation of plant boundary is required with clear understanding of raw material input, Energy input, Power Import/Export, Intermediary product Import/Export, Colony Power, Construction/

Others Power, Power supplied to other Ancillary unit outside the plant boundary. A typical sample of Plant boundary condition is represented below



Figure 13: Figure 14: Ex-GtG boundary for Cement Sector

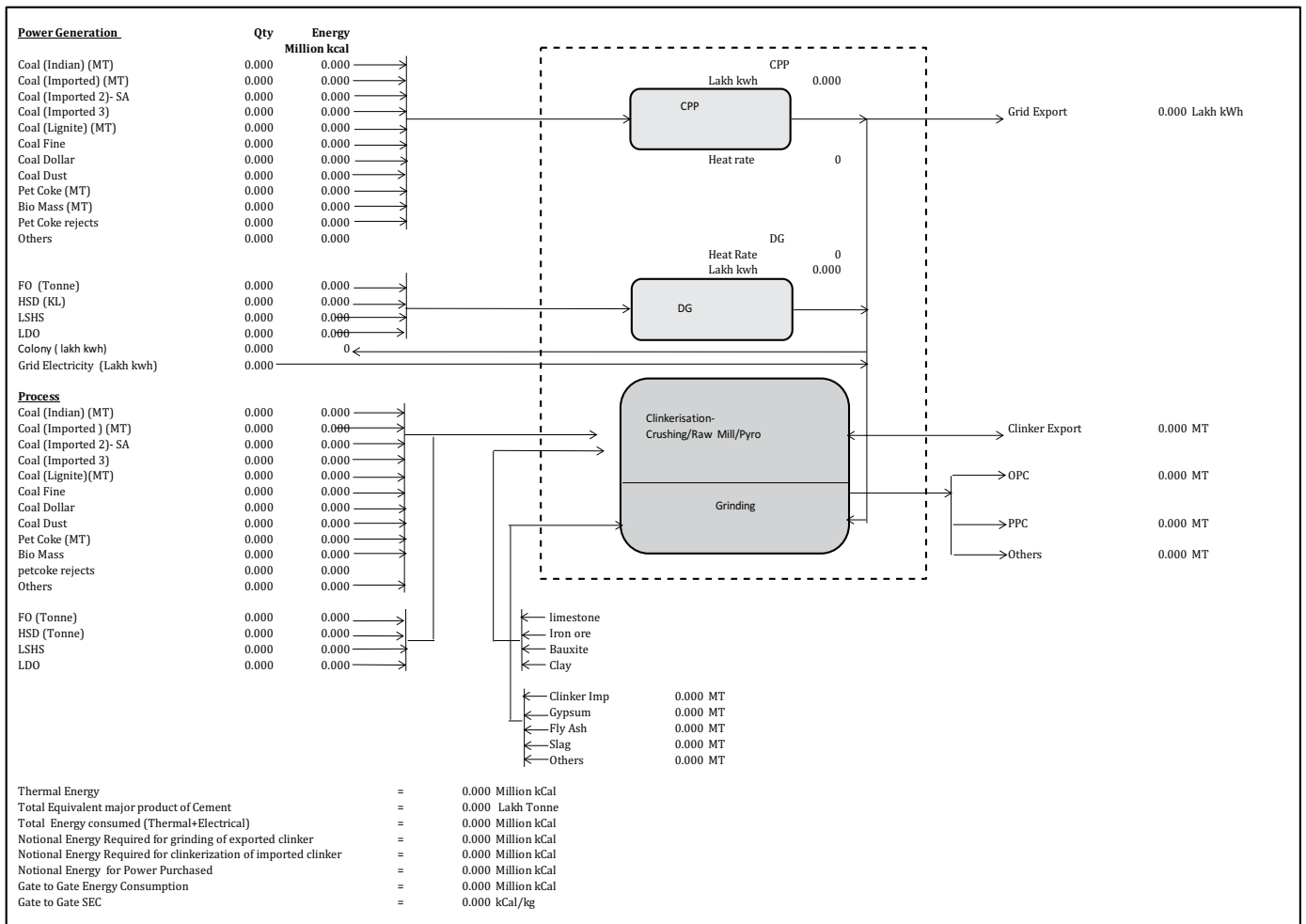

10. Mass and Energy balance verification account the Clinker stock difference and Clinker The clinker balance verification is required Import export. Similarly Energy balance up from Cement produced and Clinker factor to clinkerisation could be verified as per the with actual clinker produced by taking into tabulated formulae

Table 18: Mass and Energy balance

Mass Balance Verification (A=B)							
Clinker Balance							
Sr No	Description	Unit	Year 1, 2007-08	Year 2, 2008-09	Year 3, 2009-10	Year 4, 2014-15	Remarks
A	Equivalent Clinker from total cement produced: [OPC x CFOPC]+[PPC x CFPPC]+[PSC x CFPSC]	Lakh tonnes					
B	Clinker Produced: Total Clinker Produced + (Clinker Imported- Clinker Exported)+(Opening Clinker Stock-Closing Clinker Stock)	Lakh tonnes					





Sr No	Description	Unit	Year 1, 2007-08	Year 2, 2008-09	Year 3, 2009-10	Year 4, 2014-15	Remarks
	% Variation	$(A-B) \times 100/A$					
<b>Energy Balance Verification(C=D)</b>							
C	FinalSEC (Before Normalisation)	kcal/kg equivalent cement					
D	(Thermal SEC for Clinkerization * PPC Clinker Factor) + (Electrical SEC for Clinkerization in thermal equivalent * PPC Clinker Factor) + (Electrical SEC for Cement grinding in thermal equivalent)	kcal/kg equivalent cement					
	% Variation	$(C-D) \times 100/C$					

- |   |   |
|---|---|
| <p>11. Section wise Screen shot of SCADA from CCR/DCS is to be included in the verification report</p> <p>12. Raw material input in the Plant boundary to be recorded for inclusion in the verification report</p> <p>13. Heat balance of Kilns (Kiln wise)for the assessment year is required to be included in the verification report with boundary and understanding on CV basis i.e., NCV or GCV of fuel</p> | <p>14. Calibration records of all weighing and measurement system with frequency of calibration to be included in the verification report</p> <p>15. Clinker Factor Verification<br/>The Clinker factor calculation is to be documented and produced in the verification report, the verification could be done by taking following factor into account from the pro-forma A1-A20</p> |
|---|---|

**Table 19: Clinker Factor calculation**

Item	Unit	Year1	Year2	Year3	Year 4	Remarks
Gypsum % in Cement	%					
Clinker used for PPC	tonne					
Clinker used for OPC	tonne					
Clinker used for PSC	tonne					
Clinker Used for Cement	tonne					
Gypsum used in OPC	tonne					
Gypsum used in PPC	tonne					
Gypsum used in PSC	tonne					
Clinker factor for PPC	factor					
Clinker Factor for OPC	factor					
Clinker Factor for PSC	factor					

- |  |   |
|--|---|
| <p>16. Establishment of clear inclusion and exclusion from the plant boundary is maintained as in the baseline year.</p> | <p>17. Some of the factors, which are not covered in the cement sector pro-forma, the EmAEA is required to report it separately</p> |
|--|---|



#### 7.4. Annexure IV: Fertilizer

Fertilizer industry is maintaining an elaborate system of measurement and reporting of production and energy data in the form of “Technical Operating Data (TOP)”, as per the guidelines of Fertilizer Industry Coordination Committee (FICC), Department of Fertilizers. The TOP data is also audited by cost accountant. TOP data can be accepted as such. In case of multi-product plants, distribution of raw materials, power, steam and other utilities to be segregated and quantities allocated for urea production are to be brought out distinctly.

##### 1.0 Measurement & recording

In the following table, items have been identified, which are required for calculating material &

energy balance at battery limit of the complex. Against each item, following information is to be furnished :-

- a) Measuring device: Name, tag number, model, location
- b) Accuracy level of measurement or date of last calibration. Correction factors (if any)
- c) Type of record: Data logger/ digital recorder, charts, direct reading/log book/ log sheet etc.
- d) Frequency of reading: Hourly, shift wise, daily, periodically
- e) Whether the quantities are ascertained by material balance?
- f) Stock verification

**Table 20: Material and Energy balance of Fertilizer sector**

Sr. No.	Item	Unit	Measuring device Name/ tag no/model/ location	Accuracy level / correction factors ( if any)	Records Type/ Location	Frequency of reading	Remarks
1.0	<b>Final/ intermediate products</b>						
1.1	<b>Urea production</b>	MT					
1.2	<b>Ammonia</b>						
1.2.1	Production	MT					
1.2.2	Consumption for urea	MT					
1.2.3	Consumption for other products	MT					
1.2.4	Sent to storage	MT					
1.2.5	Received from storage	MT					
1.2.6	Export	MT					
2.0	<b>Input raw materials</b>						
2.1	Natural gas						
2.1.1	Properties						
a	GCV	Kcal/ SCM					
b	NCV	Kcal/ SCM					
2.1.2	Total receipt						
a	Main receiving station	MMSCMD					



Sr. No.	Item	Unit	Measuring device Name/ tag no/model/ location	Accuracy level / correction factors (if any)	Records Type/ Location	Frequency of reading	Remarks
2.1.3	Distribution						
a	Reformer feed	MMSCMD					
b	Reformer fuel	MMSCMD					
c	Gas turbine	MMSCMD					
d	HRU	MMSCMD					
e	Boilers	MMSCMD					
f	Others	MMSCMD					
2.2	<b>Naphtha</b>						
2.2.1	<b>Properties</b>						
a	Sp. Gravity	gm/cc					
b	GCV	Kcal/kg					
c	NCV	Kcal/kg					
2.2.2	<b>Total receipt</b>						
a	Volume	kl					
b	Weight	MT					
2.2.3	<b>Distribution</b>						
a	Reformer feed	MT					
b	Reformer fuel	MT					
c	Others	MT					
2.3	<b>Diesel</b>						
2.3.1	<b>Properties</b>						
a	Sp. Gravity	gm/cc					
b	GCV	Kcal/kg					
c	NCV	Kcal/kg					
2.3.2	<b>Total receipt</b>						
a	Volume	kl					
b	Weight	MT					
3.3	<b>Distribution</b>						
a	DG Sets	kl					
b	Others						
2.4	<b>Furnace oil/LSHS etc.</b>						
2.4.1	<b>Properties</b>						
a	Sp. Gravity	gm/cc					
b	GCV	Kcal/kg					



Sr. No.	Item	Unit	Measuring device Name/ tag no/model/ location	Accuracy level / correction factors (if any)	Records Type/ Location	Frequency of reading	Remarks
c	NCV	Kcal/kg					
2.4.2	<b>Total receipt</b>						
	Volume	kl					
	Weight	MT					
2.4.3	<b>Distribution</b>						
a	Boiler	MT					
b	Other furnaces (specify)	MT					
c	Misc (if any)						
2.5	<b>Coal</b>						
2.5.1	<b>Properties</b>						
a	GCV	Kcal/kg					
b	NCV	Kcal/kg					
2.5.2	<b>Total receipt</b>						
a	Weight	MT					
2.5.3	<b>Distribution</b>						
a	Boilers(1+2+3)	MT					
b	Others (specify)	MT					
c	Stock variation						
2.6	<b>Any other fuel</b>						
3.0	<b>Steam</b>						
3.1	<b>Production</b>						
3.1.1	Boiler (Individual)						
3.1.2	GTG/HRU						
3.1.3	Service/auxiliary boiler						
3.1.4	Others						
3.2	<b>Consumption</b>						
3.2.1	Steam turbo generator						
3.2.2	Ammonia plant						
3.3.3	Urea plant						
3.3.4	Others						

2. Material balance of all inputs at battery limit of entire complex

Following information is to be filled-in as follows:-

(i) One month having best operation as per TOP.

(ii) For financial year, as per TOP.



**Table 21: Material balance of all inputs in Fertilizer sector**

Sr. No.	Item	Unit	Received at plant battery limit	Allocated for urea production	Allocated for other products	Difference if any	Remarks
1.0	<b>Purchased items</b>						
1.1	Purchased power	MWh					
1.2	Natural gas	MMSCMD					
1.3	Naphtha						
a	Volume	Kl					
b	Weight	MT					
1.4	Diesel	Kl					
1.5	Furnace oil /LSHS etc.						
a	Volume	Kl					
b	Weight	MT					
1.6	Coal	MT					
1.7	Any other fuel						
2.0	Steam						
2.1	Production						
2.1.1	Boiler ( Individual)	MT					
2.1.2	GTG/HRU	MT					
2.1.3	Service/auxiliary boiler	MT					
2.1.4	Others	MT					
2.2	Consumption	MT					
2.2.1	Steam turbo generator	MT					
2.2.2	Ammonia plant	MT					
2.2.3	Urea plant	MT					
2.2.4	Others	MT					
3.0	<b>Power</b>						
3.1	<b>Generation</b>	MWh					
3.1.1	GTG	MWh					
3.1.2	Others	MWh					
3.2	<b>Consumption</b>						
3.2.1	Ammonia plant	MWh					
3.2.2	Urea plant	MWh					
3.2.3	Others	MWh					

**3. Pro-forma**

**a. Pro-forma**

Under the PAT scheme, all DCs are required to fill-in and submit to BEE, Pro-forma, which is mandatory, with following salient features:

**i. Plant capacity, production & capacity utilization**

- Installed capacity
- Production
- Capacity utilization



- ii. Purchased electricity – Purchased quantity, cost, consumption
- iii. Generated electricity through DG/ turbo gen/ gas turbine/ co-generation
- iv. Fuels – Gaseous (NG, LNG), Liquid (Naphtha, fuel oil, diesel) solid (coal, coke) – Purchased quantity, calorific value (GCV).
- v. Consumption of energy input for
  - Power generation
  - Process raw material
  - Process heating
- vi. Using waste as fuel
- vii. Use of non-conventional energy (Solar, wind, etc)
- ix. Total energy input at BL

**b. Sector Specific Pro-forma**

Keeping in view the special requirements in fertilizer sector, the Pro-forma has been modified with following changes:-

- i. Plant capacity is reported in following formats:-
  1. **Name plate capacity:** The original name plate capacity at the time of installation of plant.
  2. **Re-assessed capacity:** As revised by “Fertilizer Industry Coordination Committee (FICC) “ in the year 2002.
  3. **Baseline production:** As worked out (for urea product only) under PAT scheme. It is an average of production for three baseline years viz 2007-08, 08-09, 09-10.
  4. **Re-vamp capacity:** Subsequent to baseline period i.e. 2007-10, some plants carried out major revamp to enhance capacity further. The capacity is as reported by DCs to Department of Fertilizers.

**ii. Calorific value of fuel**

In fertilizer sector, all the energy calculations are based on net calorific value (NCV) of fuel. NCV will also be furnished along with GCV.

**iii. Total inputs at plant battery limit**

In the existing Pro-forma, only the inputs, which are allocated for urea production, are furnished. Modified Pro-forma, provides for furnishing total inputs at plant battery limit in addition to the inputs allocated for urea product.

**iv. Quantity of natural gas**

Presently, natural gas is being received from a number of sources. Instead of giving quantity of natural gas received from different sources separately, total quantity shall be furnished at one place only. However break up of this quantity may be furnished for Feed and fuel along with respective NCV. Other fuels which are not in use in fertilizer sector have been removed.

**4. Annexure to Pro-forma**

The Pro-forma being of generic nature does not contain information specific to fertilizer sector. Therefore, additional technical information is furnished through “Annexure to Pro-forma. Information furnished in Annexure to Pro-forma is as following:

- A. Installed capacity, production, CU, on-steam days for ammonia / urea for base 5 years.
- B. Installed capacity has been substituted with re-assessed capacity.
- C. Inputs to Ammonia Plant
  - NG/RLNG/LNG/PMT ( Feed, fuel) – Quantity, NCV
  - Naphtha ( Feed, fuel) – Quantity, NCV



- Steam / power - Quantity, conversion factor
- Credits / debits - DM Water heating, LP steam export etc.
- Ammonia production

**D. Inputs to Urea Plant**

- Ammonia consumption for urea
- Power/steam

- Credits/debits- DM Water heating, LP steam export etc.

E. Conversion factor for power generated.

F. Heat value of steam generated.

G. Information available in log sheets, log books, data logger print outs and other plant documents need to be verified with appropriate references.

**5. Plant battery limit block diagram**

Block diagram showing total energy input at Plant BL as well as credit / debit of energy at intermediate stages for establishment of " Base Line SEC"  
To be filled-in by Designated Consumers ( DC's)

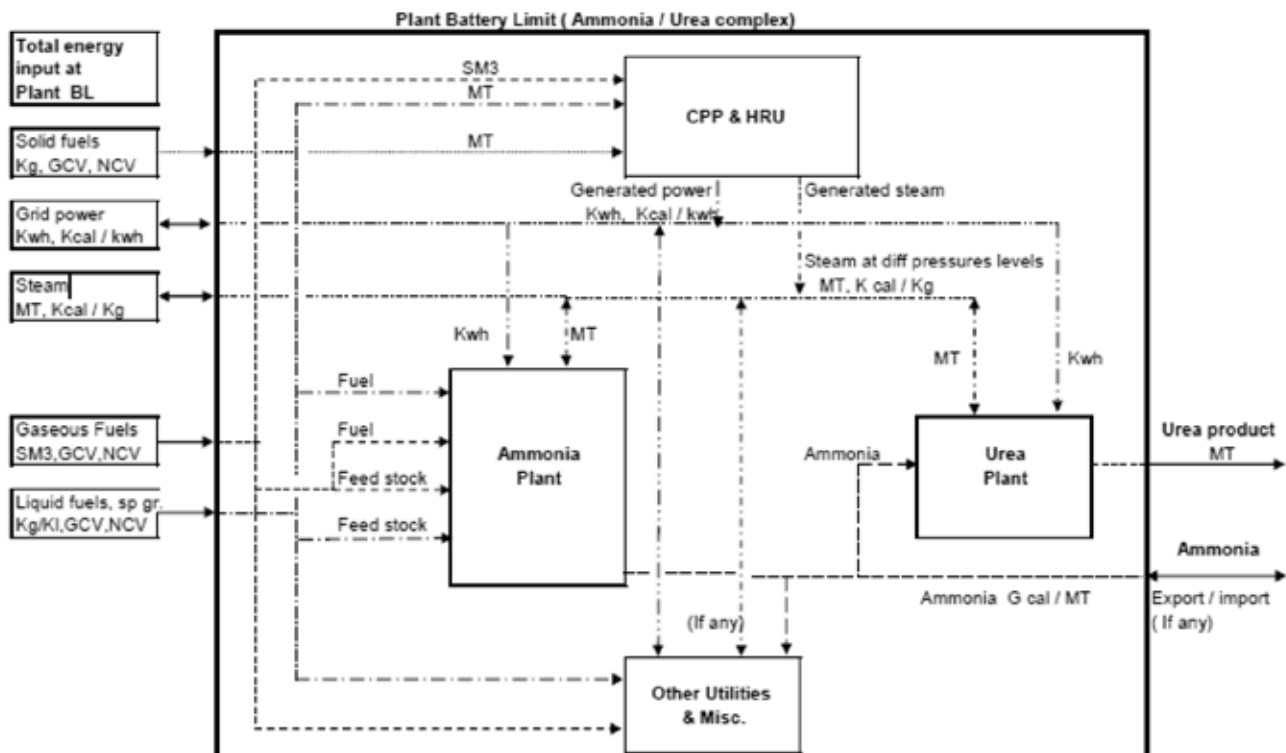

**6. Data not available in Pro-forma and Annexure - 1**

- Fuel input to boilers
- Waste gases available from ammonia/ urea plants and fed to boilers.
- Quantity of steam produced.
- Other energy inputs like pre-heated DM water

- Calculations for conversion factors of steam/power.

a. Additional information in Block diagram

The illustrative block diagram in sections - 5 above, when, filled adequately, incorporates missing information.

i. It depicts all inputs at plant battery limit, which may be



- consumed for production of urea as well as other products.
- ii. It also depicts all inputs allocated for urea production.
- iii. Gives details on various imports/exports, debit/credit etc.
- iv. One set of sample calculations of gate-to-gate energy balance to be furnished by DC.
- v. Basis of calculations, conversion factors, assumptions, import/export, credit/debit etc; to be mentioned specifically.

### 7. Procedure for calculation of specific energy consumption (SEC)

In general specific energy consumption (SEC) is calculated by dividing total energy input at battery limit by final product. However, in case of ammonia / urea complex, part of the input energy is utilized for manufacturing ammonia wherein Carbon-di-oxide (CO<sub>2</sub>) is also produced as by-product. Ammonia and CO<sub>2</sub> are then reacted to produce urea. Part of the steam/power energy is consumed in urea plant. Further, full quantity of ammonia produced is not necessarily consumed for urea manufacture. Part of ammonia may go to storage or export. Similarly, part of steam / power may be either exported or imported. Therefore, in fertilizer sector, SEC of urea cannot be calculated directly by dividing total energy input by urea product. Following procedure is to be adopted for calculating SEC:-

- a. Allocation of fuel for production of ammonia, power/steam and other products/facilities (wherever applicable).
- b. Calculation of conversion factor for power generated (Kcal/Kwh) and its distribution.
- c. Conversion factor for purchased power (taken as 2860 Kcal/Kwh).
- d. Calculation of heat value of steam produced (Kcal/Kg) and its distribution.
- e. Calculation of SEC for ammonia by considering the following:-
  - i. Feed & fuel energy input to ammonia plant directly
  - ii. Allocation of steam/power to ammonia plant along with conversion factors.
  - iii. Credit/debit of energy at ammonia plant battery limit like pre-heating of DM water, burning 'Off gases' in boiler furnace etc.
- f. Calculation of SEC for urea by considering the following:-
  - i. Allocation of ammonia, separately as manufactured or purchased, for urea production.
  - ii. Allocation of steam/power to ammonia plant along with conversion factors.
  - iii. Credit/debit of energy by way of export of steam, burning vent gases etc.

Sr. No.	Description	Unit	Illustrative figures	Actual for 2014-15	Remarks
1.0	<b>Overall plant battery limit</b>				
1.1	<b>Inputs</b>				
1.1.1	Natural gas ( NG)				
a	Quantity	MMSCM			
b	NCV of NG	Kcal/SCM			
1.1.2	Naphtha				
a	Quantity	kl			





Sr. No.	Description	Unit	Illustrative figures	Actual for 2014-15	Remarks
b	NCV of naphtha	Kcal/lit Kcal/kg			
c	Density of naphtha	gm/cc			
1.1.3	Grid power	MWh			
1.1.4	Steam	MT			
1.1.5	Ammonia	MT			
1.2	Output				
	Urea	MT			
	Power export	kWh			
2.0	<b>CPP/HRU</b>				
2.1	<b>Input</b>				
2.1.1	Natural gas	MMSCM			
2.2	Output				
2.2.1	Power	MkWh			
	Heat rate	Kcal/kWh			
2.2.2	Steam	MT			
	Heat content	Kcal/kg			
3.0	<b>Ammonia Plant</b>				
3.1	<b>Input</b>				
3.1.1	NG feed	MMSCM			
3.1.2	NG fuel	MMSCM			
3.1.3	Naphtha feed	kl			
3.1.4	Naphtha fuel	kl			
3.1.5	Steam	MT			
3.1.6	Power	MkWh			
3.2	<b>Output</b>				
3.2.1	Ammonia product	MT			
4.0	<b>Urea Plant</b>				
4.1	<b>Input</b>				
4.1.1	Ammonia	MT			
4.1.2	Steam	MT			
4.1.3	Power	MkWh			
4.2	<b>Output</b>				
4.2.1	Urea product	MT			
5.0	<b>Service boiler / Utilities</b>				
5.1	<b>Input</b>				
5.1.1	NG Fuel	MMSCM			
5.1.2	Naphtha fuel	kl			



## 8. Gate to Gate specific energy consumption (SEC)

### i. Overall material & energy balance

An illustrative material & energy flow diagram of an ammonia/urea fertilizer complex is given below

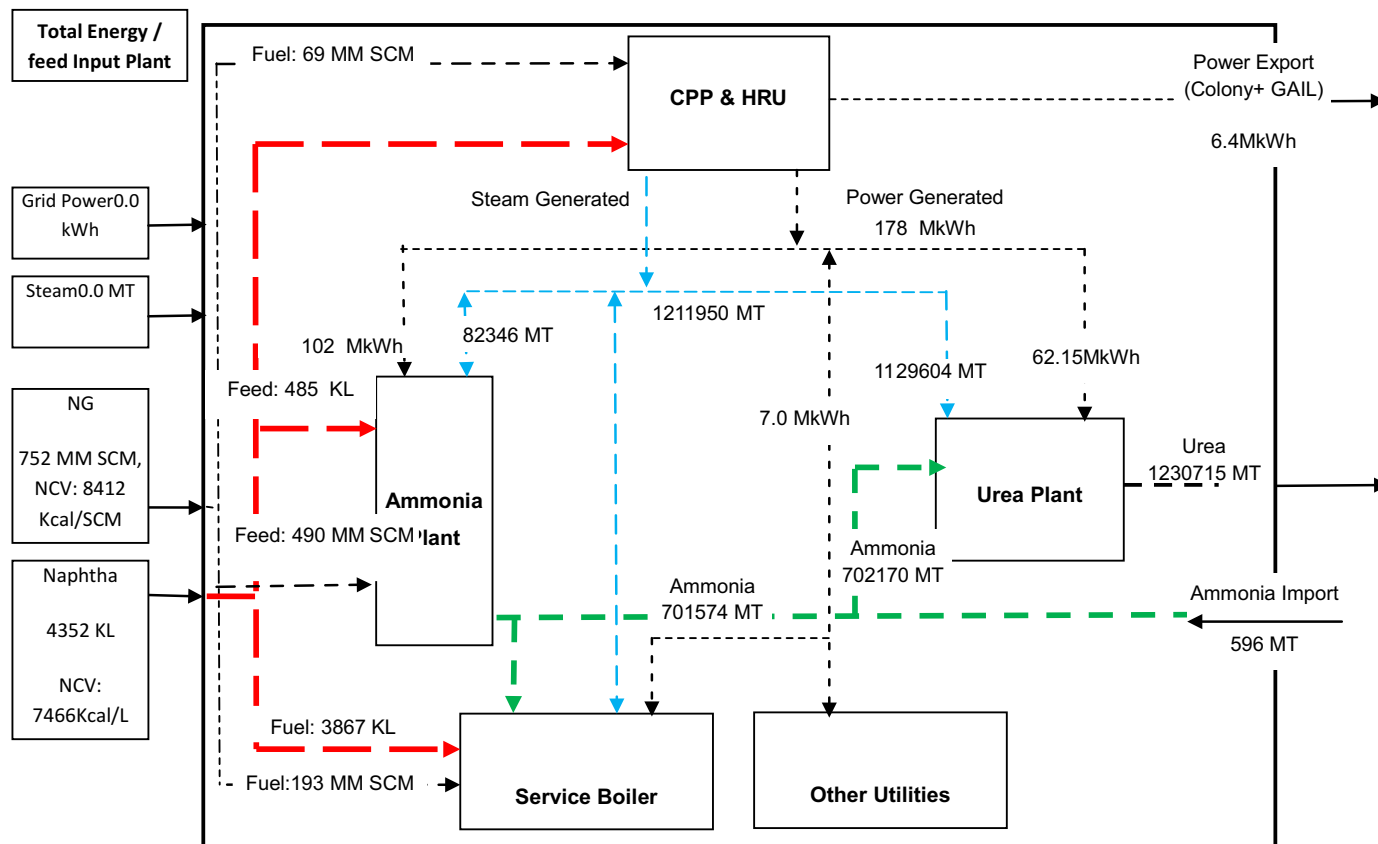

Figure 16: Overall Material and Energy balance. Figures mentioned above are indicative and used for representational purpose only . The actual data will vary from unit to unit .

## II. CALCULATION OF SPECIFIC ENERGY CONSUMPTION (SEC) OF AMMONIA

### (a) Material balance of Natural Gas

Description	Quantity (MM SCM)	NCV (Kcal/SCM)	Heat content (Gcal) 2 x 3	Remarks
1	2	3	4	
Total input				
	752	8412	6325824	
Distribution				
CPP/HRU	69	8412	580428	
Reformer feed	490	8412	4121880	
Reformer fuel	193	8412	1623516	



(b) Material balance of Naphtha

Description	Quantity (KL)	NCV (Kcal/ L)	Heat content (Gcal) 2 x 3	Remarks
1	3	2	4	5
Total input				
	4352	7466	32492	
Distribution				
Reformer feed	485	7466	3621	
Service boiler	3867	7466	28871	

c) Energy balance in Ammonia Plant

Item	Unit	Quantity	NCV/ Heat value	Heat content Gcal	Specific energy consumption
Ammonia production	MT				
NG feed	MM SCM				
NG fuel	MM SCM				
Naphtha feed	MT				
Naphtha fuel	MT				
Steam	MT				
Power	MkWh				
Total feed energy	Gcal				
Total fuel energy	Gcal				
Power + steam	Gcal				
Total SEC	Gcal/MT				
Non plant energy	Gcal/MT				
SEC including non-plant energy	Gcal/MT				

(d) Energy balance in Urea Plant

Item	Unit	Quantity	NCV/ Heat value	Heat content Gcal	Specific energy consumption
Urea production	MT	1230715			
Ammonia feed	MT	701574	7.691	5395806	4.384
Steam	MT	1129604	743	839295	0.682
Power	MkWh	62150	511	31759	0.026
Total energy	Gcal			6266860	
Total SEC	Gcal/MT				5.092
Non plant energy	Gcal/MT				0.079
SEC including non plant energy	Gcal/MT				5.171



## 9. Computing Baseline data

Under first cycle of PAT scheme, the baseline period constitutes the years 2007-08, 08-09 and 2009-10. Urea product has been taken as basis for calculating Specific energy consumption “SEC”.

### a. Production

Baseline production of urea is obtained by averaging urea production for three baseline years i.e. 2007-08, 08-09, 09-10. Production during target year (2014-15) is reported in the following table.

Sr. No.	Description	Unit	Baseline data				Assessment year
			2007-08	2008-09	2009-10	Average	2014-15
1.0	Urea product						
1.1	Installed capacity	MT				n.a.	
1.2	Actual production	MT					
1.3	Capacity Utilization	%				n.a.	

### b. Specific energy consumption (SEC)

Baseline specific energy consumption (SEC) of urea is obtained by weighted average

for three baseline years i.e. 2007-08, 08-09, 09-10. Specific energy consumption (SEC) during target year (2014-15) is reported in the following table.

Sr. No.	Description	Unit	Baseline data				Assessment year
			2007-08	2008-09	2009-10	Total	2014-15
1.0	Urea production	Tonnes				n.a.	
1.1	SEC	Gcal/ MT				n.a.	
1.2	Total energy	Gcal					
1.3	Weighted average	Gcal/MT	n.a	n.a	n.a		

## 10. Normalization factors

PAT procedure provides for “Normalization” of reported data based on capacity utilization factor, when plant load factor (PLF) has a deviation of more than 30%. The PAT procedure also provides for normalization by statistical analysis methods. In fertilizer sector, apart from capacity utilization, there are some other important factors viz. number of forced shut down of the plant, use of naphtha due to unavailability of natural gas, quality of coal and commissioning period after major revamp of the plant, which also affect specific energy consumption of product. Identified causes of un-productive energy consumption on account of factors, which are beyond the control of the plant are as follows:

- (i) Forced shut down of the plant and subsequent Cold start up
- (ii) List of critical equipment, which on failure, cause forced shut down.
- (iii) Plant operation at low load
- (iv) Reduction of ammonia synthesis and CO shift catalyst
- (vi) Use of naphtha due to non-availability of gas
- (vi) Deterioration in quality of coal

For calculating the unproductive energy consumption against individual factor, formats were developed showing illustrative calculations.



### a. Low capacity utilization

In addition to the reasons for lower capacity as given in PAT document, lower capacity utilization due to following reasons has also been considered for normalization (i) shortage of raw material including feed, fuel, water, electricity etc. (ii) high cost of inputs leading to unviable urea production beyond certain capacity (iii) major equipment failure (iv) force majeure.

Factors like shortage of raw materials (mainly the gas), decline in market demand, change in Govt. policy etc. are beyond the control of DCs. These factors may force the plant to be operated at lower capacity, thus causing adverse effect on energy consumption. In such cases, normalization shall be allowed as follows.

#### i. Pre-requisites for Normalization

1. A DC shall furnish detailed and convincing reasons with supporting documents for reduction in capacity utilization, due to factors, beyond their control.
2. Following criteria shall be adopted:-
  - a) No compensation shall be allowed if the capacity utilization of urea plant on annual basis is 95% or above.
  - b) Compensation shall be allowed for capacity utilization between 70-95%.
  - c) Below 70%, the data shall be discarded.
3. The claim will be based on Technical operating data (TOP), which is being reported to Fertilizer Industry Coordination Committee (FICC) of Department of Fertilizers, Govt. of India.
4. Normalization due to low capacity

utilization will be considered only in one of the plants i.e. either ammonia or urea.

5. Subsequent to the baseline year i.e. 2007-10, some DCs have carried out major revamp of their plant for capacity enhancement in line with New Investment Policy for urea notified by the Govt. in 2008. Govt. recognized enhanced capacity, while reimbursing cost of production under the pricing policy. The enhanced capacity shall be considered, while calculating capacity utilization for normalization, subject to confirmation from DoF, Government of India and also verification certificate issued by an Accredited Energy Auditor to DC which seek to declare their enhanced installed capacities, production and energy use. Cost of this audit will be borne by the DC. Check tests of such verification could be carried out by BEE, if needed.
  6. Some plants are having ammonia plant capacity higher than the quantity of ammonia required for urea production and thus, diverting surplus ammonia for production of other products or direct sales. In such cases, due to Govt. policy and/or market conditions, consumption of surplus ammonia for production of other products becomes unviable and under these circumstances, ammonia plant is operated at lower capacity, thus resulting in higher energy consumption per MT of ammonia, which also get transferred to urea, even if the urea plant is operated at full load; Normalization shall be allowed.
  7. In case of ammonia / urea complex having ammonia capacity matching with urea production, capacity utilization of urea plant shall be considered.
- #### ii. Calculation of normalization factor
1. Based on the operating data collected from plants at 100%, 85% and 70% plant load, average normalization



factor works out to be 0.02 Gcal per MT of urea per percentage reduction in plant load below 95% up to 70%.

2. Impact of Lower Capacity utilization shall be worked out as follows:-

- a. Maximum permissible value (Gcal/ MT urea) = (95 - % Capacity utilization) \* 0.02.
- b. Actual unproductive energy (Gcal/ MT urea) = Annual Energy, Gcal/MT of Urea - Weighted Average of Monthly Energy Consumptions for the months with Capacity Utilization of 100% or more
- c. Lowest of the either (a) or (c) shall be considered for allowing the impact of lower capacity utilization.

3. Impact of Lower Capacity utilization of plants where ammonia is surplus than required for urea production, shall be worked out as follows:

- a. Maximum permissible value ( Gcal/ MT ammonia) = (95 - % Capacity utilization of ammonia plant) \* 0.02 Gcal.
  - b. Actual unproductive energy (Gcal/ MT urea) = Annual Energy, Gcal/ MT of ammonia - Weighted Average of Monthly Energy Consumptions for the months with ammonia plant Capacity Utilization of 100% or more
  - c. Lowest of the above two shall be considered for allowing the impact of lower capacity utilization. In such cases, normalization due to low capacity utilization (i.e. <95%) will be allowed only in one of the plants i.e. either ammonia or urea.
4. Capacity utilization for urea plant will be calculated based on "Baseline urea Production".
- iii. Supporting data / documentation Data shall be maintained in the following formats:-

**A. Month-wise production & energy consumption during the year**

Sr. No.	Month	Ammonia				Urea			
		On stream	production	CU	SEC	On stream	production	CU	SEC
		days	MT	%	Gcal/MT	days	MT	%	Gcal/MT
1	April								
2	May								
3	June								
4	July								
5	August								
6	September								
7	October								
8	November								
9	December								
10	January								
11	February								
12	March								



B. Data for best operating months

Sr. No.	Best operating month	Ammonia production	CU	Urea production	CU	SEC Ammonia	SEC Urea	Reference
		MT	%	MT	%	Gcal/ MT	Gcal/ MT	

- (i) Take the month in which , plants have run for all the calendar days.
- (ii) Capacity utilization during the month should be equal to or above 100%.

**b. Cold startup of the plant after forced shut down**

In case of sudden failure of a critical equipment as per the list below, or external factors (as notified), ammonia plant undergoes a forced shut down. Restarting the plant from cold conditions (Cold start up) , consumes unproductive energy and shall be normalized.

**i. Pre-requisites for Normalization**

A. The list of critical equipment failure of which leads to complete shutdown of plant and consequent cold start up, allowed under this normalization factor is given below :-

1. Primary Reformer
2. Secondary Reformer
3. Heat Exchange Reformer
4. Reformed Gas Boiler
5. Carbon dioxide absorber and stripper
6. Air, Refrigeration and synthesis compressors
7. Synthesis converters
8. Synthesis Gas Waste Heat Boilers
9. High pressure urea reactor, stripper and carbamate condenser
10. Carbon dioxide compressor

11. Utility boiler furnace
12. Gas turbine/HRSG
13. Cooling Tower
14. Major Fire leading to complete shutdown of plant and cold startup
15. Turbo generator along with GTG
16. Purifier
17. CO Shift Converter

B. The Designated Consumer (DC) shall furnished a detailed report on failure of such equipment and its impact on energy consumption.

C. The Designated Consumer shall declare with back up documentation, what portion of such unproductive consumption during the month is due to cold shutdown and startup activity.

D. This actual energy loss due to shut down and cold startup in Gcal/MT of Urea shall be compensated, subject to maximum of 0.03 Gcal/MT of Urea.

**ii. Calculation of normalization factor**

A. Energy loss during the month(s) for which additional cold startup is being claimed shall be calculated as follows:-

- (i) (Monthly Energy per MT of Ammonia during the month-Weighted Average Monthly Energy Consumption for the months with 100% on-stream days) X Monthly Ammonia production for the month of Startup.



- (ii) This Energy Loss shall be divided by Annual Urea Production to identify total unproductive loss in a month.
- (iii) The Designated Consumer shall declare what portion of such unproductive consumption during the month is due to cold shutdown and startup activity.
- (iv) This actual energy loss due to shut down and cold startup in Gcal/ MT of Urea shall be compensated, subject to maximum of 0.03 Gcal/ MT of Urea.
- (v) The failure of critical equipment leading to complete shutdown of plant and consequent cold start up, allowed under this normalization factor is given at Annexure -

**iii. Documentation**

Sr. No.	Description	Unit	2007-08	2008-09	2009-10	2014-15
1	Ammonia production	MT				
2	Urea production	MT				
3	Total no of cold start up	Nos				
4	Cold start up due to failure of major equipment	Nos				
5	For each start up					
a	Duration	hours				
b	Energy consumed	Gcal				

Note: For each shut down / cold start up, information to be filled-in separately.

**c. Use of naphtha**

A. Using part naphtha involves additional energy consumption as follows:-

- a) For each startup of facilities to use naphtha as feed including pre-reformer
- b) For the period of use of naphtha as feed
- c) For the period of use of naphtha as fuel

B. DCs shall furnish detailed and convincing reasons with supporting documents for use of naphtha due to non-availability of gas on account of factors, beyond their control.

**i. Pre-requisites for Normalization**

- A. As per directives from Department of Fertilizers, Govt. of India, use of naphtha is to be discontinued in phased manner. As such, use of naphtha is not foreseen. However, provision is being made, in case naphtha has to be used due to shortage of natural gas in future, with permission from DoF.
- B. In case of use of naphtha, DC will furnish details regarding non-availability of gas, leading to use of naphtha.

**ii. Calculation of normalization factor**

A. Following formula shall be used

$$\text{Energy loss (Gcal/MT Urea)} = (185 * S + 0.625 * N_{\text{feed}} + 0.443 * N_{\text{fuel}}) / \text{urea production in MT}$$





- S= 1 if naphtha is used as feed in startup
- S= 0 if naphtha is not used as feed in startup
- $N_{Feedc}$  = quantity of naphtha used as feed in MT.
- $N_{Fuelc}$  = quantity of naphtha/LSHS/FO used as fuel in MT.

iii. Documentation

Sr. No.	Description	Unit	2007-08	2008-09	2009-10	2014-15
1	Ammonia production	MT				
2	Urea production	MT				
3	NG consumption	MMSCMD				
4	Shortfall in NG	MMSCMD				
5	Equivalent naphtha	kl				
6	Actual naphtha used	kl				

d. **Catalyst reduction**

Fresh catalyst is in oxidized form and needs to be reduced with synthesis gas, wherein hydrogen reacts with oxygen and gets converted into water. Whole plant is operated at 60-80% load for around 48 to 120 hours, depending upon type and quantity of catalyst. Thus, replacement / reduction of **ammonia synthesis and CO shift catalysts** consumes large amount of unproductive energy. Therefore, normalization due to replacement / reduction of these catalysts will be allowed.

i. **Pre-requisites for Normalization**

A. In case of ammonia synthesis catalyst, in the older plants, oxidized form of the catalyst is used which takes around 4-5 days for reduction, causing corresponding un-productive energy consumption. Presently, "Pre-reduced catalyst" is also available, which is expensive but takes around 48 hours for reduction, thus consuming lesser un-productive energy. This aspect will be taken care, while calculating normalization factor.

B. This will be considered subject to certification by DCs and furnishing to BEE information as follows:

- (i) Year in which the catalyst were last changed along with copies of purchase order, last placed with the vendor, time taken in commissioning of catalyst, facts and figures clearly indicating and quantifying rise in the energy consumption of plant due to the replacement of this catalyst.
- (ii) Copies of purchase orders placed by units with the vendors for supply of fresh catalysts.

ii. **Calculation of normalization factor**

Adjustment shall be allowed on the basis of actual plant data, subject to a maximum of 0.04 Gcal/MT of Urea.

e. **Deterioration in quality of coal**

The quality of indigenous coal has been deteriorating gradually, thus affecting boiler efficiency adversely. The reduction in boiler efficiency due to poor quality of coal shall be compensated.

i. **Pre-Requisites for Normalization**



Weighted average of three years data shall be worked out. In case there is significant variation, then normalization factor shall be applied based on the actual impact due to the variation.

**ii. Calculation of normalization factor**

A. Quality of coal affects boiler efficiency, which shall be calculated by following empirical formula:-

$$\text{Boiler Efficiency} = 92.5 - ((50 \times A + 630(M + 9H)) / \text{GCV})$$

Where

**iii. Documentation**

**A. Coal consumption and analysis**

Sr. No.	Parameters	Unit	2007-08	2008-09	2009-10	2014-15
1	Quantity of coal used	MT				
2	GCV (Weighted average)	Kcal/kg				
3	NCV (Weighted average)	Kcal/kg				
4	<b>Proximate analysis</b>					
A	Fixed carbon	%				
B	Volatile matter	%				
C	Moisture	%				
D	Ash	%				
5	<b>Ultimate analysis</b>					
A	Carbon	%				
B	Hydrogen	%				
C	Sulphur	%				
D	Nitrogen	%				
E	Oxygen	%				

**f. Additional provisions**

i. Normalization factors to be applied during assessment year, shall also be applied on baseline data for 2007-10.

B. Provision of normalization factors is intended solely to save plants from penalties for non-achieving the saving targets, for reasons which are beyond the control of DCs. However, availing of any of the normalization factors shall render the DC ineligible for issuance of E-certificates

A = Ash content of coal (%)

M = Moisture (%)

H = Hydrogen (%)

GCV = Kcal/Kg

B. Boiler efficiency shall be converted into specific energy consumption, as follows:

Additional Energy Consumption, Gcal/MT of Urea = Energy of Coal per MT of Urea in Target Year, Gcal/MT of Urea \* (Boiler Efficiency in Base Year - Boiler Efficiency in Target Year) / Boiler Efficiency in Target Year.

under PAT scheme. Therefore DC should seek normalization only when specified energy saving target is not met due to reasons beyond control of DCs.

C. DC's claim will be examined based on Technical operating data (TOP), which is being reported to Fertilizer Industry Coordination Committee ( FICC) of Department of Fertilizers, Govt. of India as well as by auditors designated by Bureau of Energy Efficiency ( BEE).



### 7.5. Annexure V: Aluminium

1. The energy required to transport mined bauxite to refining operations within the plant boundary, alumina to smelting operations, ingots to metal processors, and scrap from collection to melting is accounted as inside transportation and considered as energy used in plant.
  2. Plant stoppages and start due to external factor: Necessary documents have to be provided by DC
  3. Proper documents on Bauxite Quality for the purpose of normalization have to be maintained and submitted to EmAEA.
  4. Refinery Mass Balance (Bauxite to alumina ratio): The DC has to provide necessary calculation document to EmAEA during M&V for verification of alumina product ratio.
  5. Smelter Mass Balance (Alumina to Molten Aluminium ratio): The DC has to provide necessary calculation document to EmAEA during M & V for verification of Molten Aluminium product ratio
  6. In Smelter Plant EmAEA has to verify BusBar Voltage drop and Anode-Cathode Distance in reduction cell.
  7. DC needs to submit HMBD of Turbine system or characteristics curve between Load and Turbine Heat Rate PLF normalization. Equivalent capacity HMBD or characteristics curve shall be used, if OEM data is not available with the DC
  8. In case of addition of new Potline, a DC shall submit all relevant design data of new Pot line to EmAEA for inclusion in the verification report
  9. The baseline SEC factor used for product equivalent will be used for assessment year product equivalent. The major product of the baseline period will be considered in the assessment year. In case if any new product is introduced in the assessment year the SEC factor of assessment year will be used for converting to equivalent major product for the assessment period.
  10. For Import or Export of Carbon Anode, DC shall be required to fill the Pro-forma the type of anode (i.e., Green Anode, Baked Anode or Rodded Anode) exported or imported in the Remarks Column. The SEC shall be for the type of Carbon Anode i.e., SEC up to the type of Carbon Anode produced. Generally for importing or exporting anodes, the energy shall be booked till the energy of baked anodes
1. Refinery
  11. Review of Section wise Specific Energy Consumption

**Table 22: Section wise Energy Consumption details**

S. No	Section	Thermal energy Consumption	Electrical Energy Consumption	kWh/tonne of Alumina	kWh/tonne of Aluminium	Remarks
1	Grinding					
2	Digestion					
3	Clarification					
4	Precipitation					
5	Calcination					



12. Plant Boundary

Demarcation of plant boundary is required with clear understanding of raw material input, energy input, power import/export, Intermediary product import/

export, Colony power, Construction power, power supplied to other ancillary unit outside of the plant boundary. Typical plant boundary conditions are produced below.

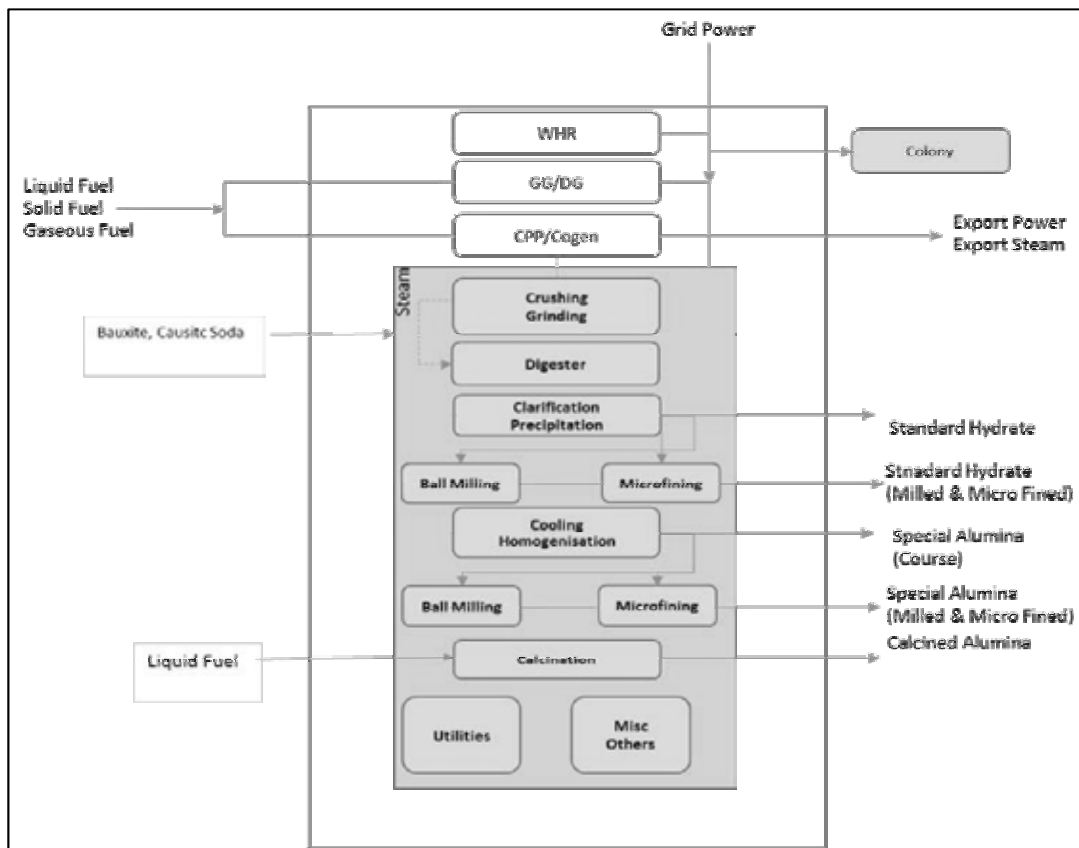

Figure 17: Ex- GtG boundary for Aluminium (Refinery sub sector)

**B. Smelter**

- 13. Carbon Anode to Molten Aluminium ratio: The DC has to provide necessary document to EmAEA during M & V. Approximately 0.45 kilograms of carbon anode were needed to produce one kilogram of aluminum
- 14. The smelter Energy consumption shall be taken up to Molten Alumina in the pro-

forma

- 15. The additional cast house product shall be converted into one product and inserted in the Product "other" details in pro-forma
- 16. The energy used in smelter for imported scrap/ cold metal for production of finished products shall be considered for product equivalent hot metal SEC calculation

**Table 23: Section wise Energy Consumption details**

S.No	Section	Thermal Energy Consumption	Electrical Energy Consumption	kWh/tonne of Anode	kWh/tonne of Aluminium	Remarks
1	Pitch					
2	Coke					
3	Baking					



**17. Electrolytic reduction energy consumption:**

**Table 24: Voltage Distribution**

S.No	Reduction Cell (Section wise)	Voltage Distribution
1	External	
2	Anode	
3	Polarization	
4	Bath	
5	Reaction	
6	Cathode	
7	Other	

**18. Plant Boundary**

Demarcation of plant boundary is required with clear understanding of raw material input, energy input, power import/export, Intermediary product import/

export, Colony power, Construction power, power supplied to other ancillary unit outside of the plant boundary. Typical plant boundary conditions are produced below

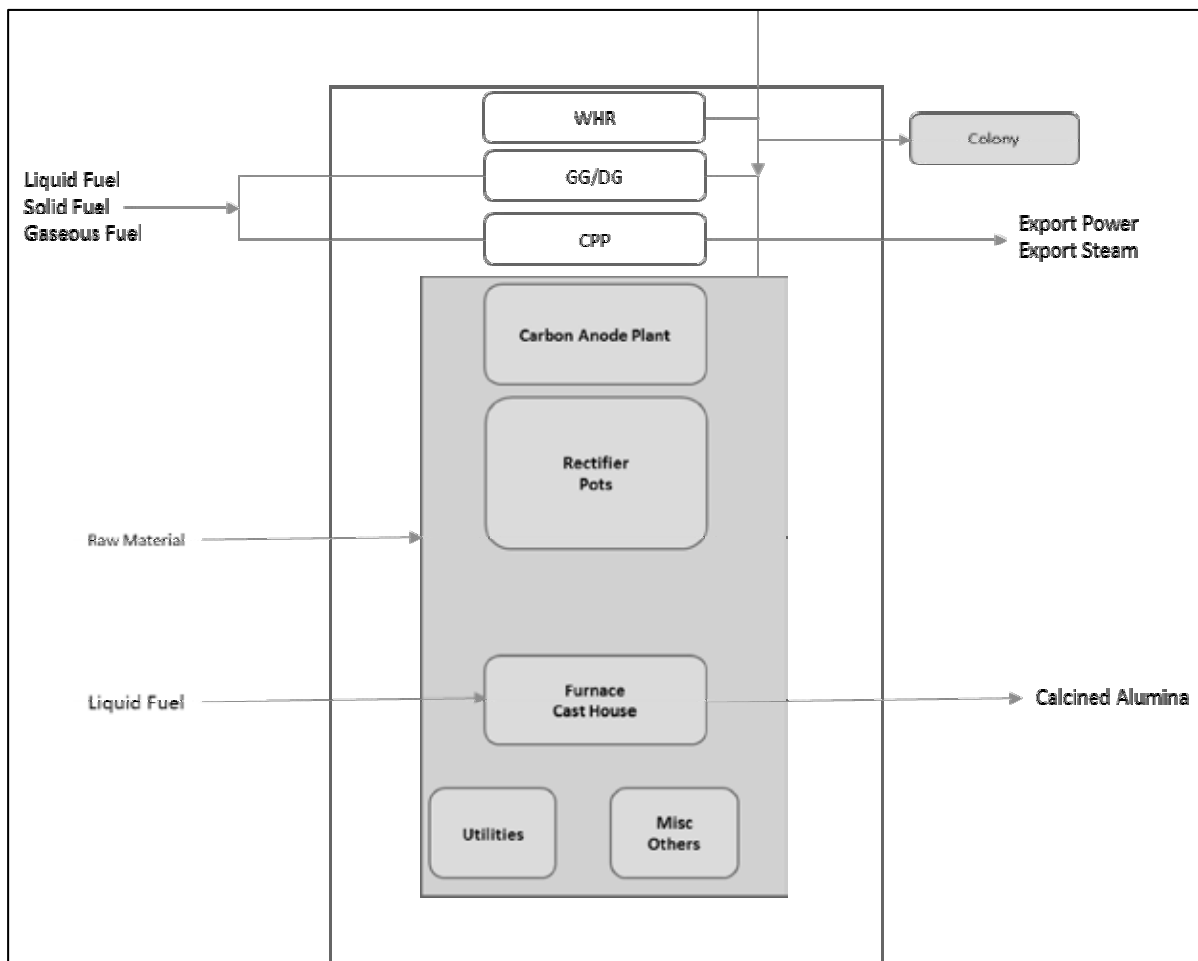

Figure 18: Ex- GtG boundary for Aluminium (Smelter sub sector)



### C. Cold Sheet

19. Necessary documents as per the instruction in Form 1 need to be provided by DC to EmAEA for verification of section wise energy consumption and Specific Energy Consumption.
20. Product equivalent of other cold rolled products shall be calculated offline to to single cold rolled product through conversion from SEC of different cold rolled product.

### 21. Plant Boundary

Demarcation of plant boundary is required with clear understanding of raw material input, energy input, power import/export, Intermediary product import/export, Colony power, Construction power, power supplied to other ancillary unit outside of the plant boundary. Typical plant boundary conditions are produced below

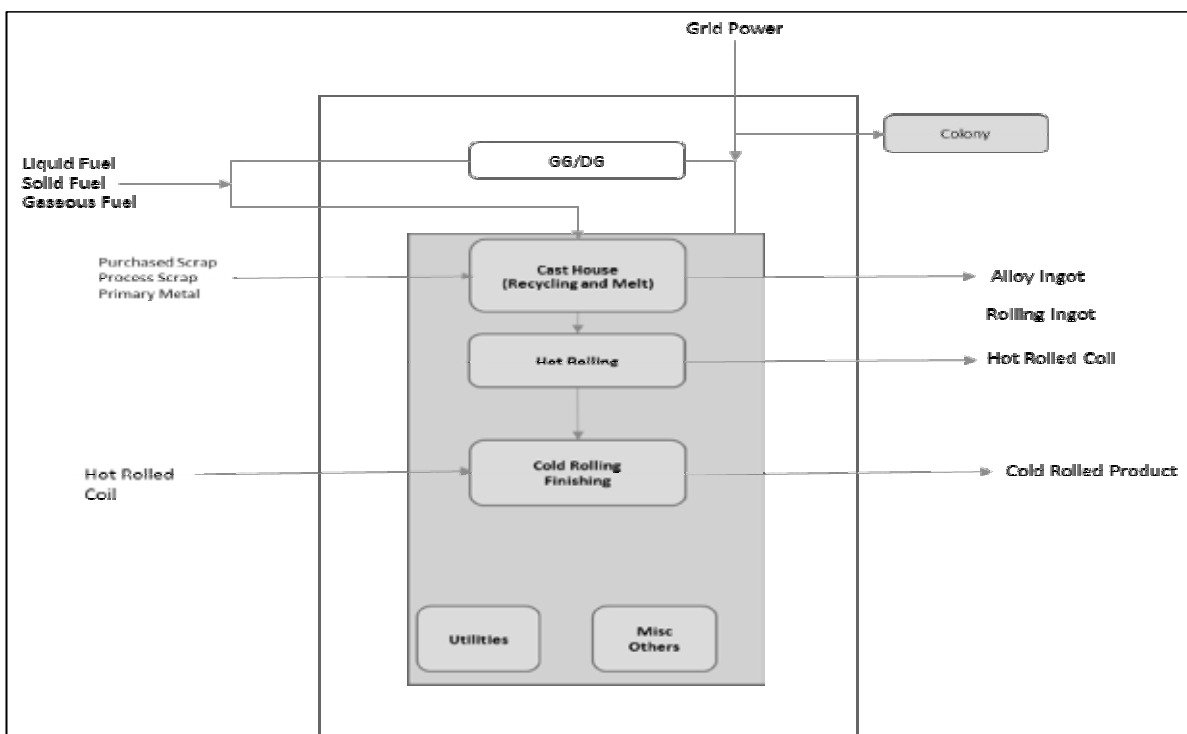

Figure 19: Ex- GtG boundary for Aluminium (Cold Sheet sub sector)

### 7.6. Annexure VI: Pulp & Paper

1. The boundary can be drawn virtually by including CPP or Cogen in the boundary limit of DCs, if nos DCs exist in a same boundary limit.
2. The captive power plant (CPP) or cogen will be taken into the virtual boundary of each DCs and accordingly import and export of power and steam will be treated as per Pro-forma data entry system.
3. If a captive power plant or cogeneration

plant caters to two or more DCs for the electricity and/or steam requirements. In such scenario, each DC shall consider such captive power plant or cogeneration plant in its boundary and energy consumed by such captive power plant or cogeneration plant shall be included in the total energy consumption. However, electricity in terms of calorific value (as per actual heat rate) and steam in terms of calorific value (as per steam enthalpy) exported to other plants shall be subtracted from the total energy consumption.



4. It is to be noted that the same fuel input needs to be considered in case CPP is being taken into the boundary limit. By import and export of energy, the energy consumption from the CPP is automatically left out for the particular DC for SEC calculation.
  5. Mill wise verification data are required to be included in the verification report
- a. The information required is shown in the flow chart for wood based pulp and paper mill
  - b. List of documents required for monitoring and verification
- in M&V format by mentioning the source and document from where data is collected. Subsequently the data may be verified from the, data provided by the DC in sector specific Pro-forma for normalization.

**A. Wood Based Mills:-**

- a. The auditors may collect details required

**Table 25: General details required in wood based Pulp and Paper Mills**

**A.1 Raw Material Details**

Type of Wood:-

Sr No	Name of the raw material	Moisture, %	Quantity, tonne/annum	Source/ document
1				
2				
3				
4				
5				

**A.2 Wood Pulp Mill (Including Raw material, Chipper , Digester , WSC, ODL , Bleach Plant, Recovery , WTP, and ETP)**

i) Pulping Processes Used

Sr No	Type of pulping	Capacity tonne/annum	Production tonne/annum	Total Yield (Including screening losses)	Source / Document
1	Chemical				
2	Semi Chemical				
3	Chemi Thermo Mechanical				
4	Other				

ii) Extended Delignification (ODL)

Sr No	Item	Unit	Value	Source / Document
1	Capacity	tonne/ annum		
2	Date of Installation of ODL Plant	Date		



iii) Bleaching

Sr No	Item	Chemical Pulp	Semi Chemical	Chemical Thermo Mechanical Pulp
1	Type of Bleaching	ECF/conv.	ECF/conv.	ECF/conv.
2	Sequence Used			
3	Bleaching Losses %			
4	Bleached Pulp Yield %			
5	Brightness of pulp, %			

Sr No	Item	Unit	Value	Source / Document
1	Capacity	Tonne/ annum		
2	Date of Installation of ECL Plant	Date		

iv) Energy Consumption in Pulp Mill

Sr No	Item	Qty	Source/ Document
1	Steam Consumption, LP/a		
2	Steam Consumption, MP/a		
3	Power Consumption, kWh/a		

v) Pulp Dryer

Sr No	Item	Unit	Qty	Source / Document
1	Capacity	Tonne/annum		
2	Production of salable pulp, t/a	Tonne/annum		
3	Energy Consumption in pulp dryer	kcal		
4	LP Steam Consumption	Tonne/annum		
5	MP Steam Consumption	Tonne/annum		
6	Power Consumption	kWh/annum		

vi) Chemical Recovery

Sr No	Item	Unit	Data	Source / Document
1	Type of chemical recovery	Conventional/Non-Conventional		
2	Total Black liquor Solids generated	Tonnes		
3	In Lime Kiln Installed	Yes/No		
4	Date of Installation of Lime Kiln I	Date		
5	Date of Installation of Lime Kiln II	Date		
6	Date of Installation of Lime Kiln III	Date		





vii) Over-all Energy consumption in pulp mill

Sr No	Item	Qty	Source / Document
1	LP Steam consumption, t/a		
2	MP Steam consumption, t/a		
3	Power consumption, kWh/a		

**A.3 Paper Machine (including stock preparation, chemical preparation / addition plant, finishing house)**

(i) Paper Machine Details

Number of Paper Machines

Item	PM-1	PM-2	PM-3	PM-4	PM-5	Source/ document
Type of paper machine						
Capacity,t/a						
Type of paper produced						
Production, t/a						
Annual weight average GSM						
<b>Energy Consumption in paper machine (including Stock Preparation, chemical addition and finishing house)</b>						
LP Steam consumption t/a						
MP Steam consumption, t/a						
Power consumption, kWh/a						

(ii) Coating / Value addition

Coating If any

Yes / No

Type of coating

online / offline

Item	Qty	Source/ document
Capacity of offline coating plant, t/a		
Production of coated paper/board, t/a		
LP Steam consumption,t/a		
MP Steam consumption, t/a		
Power consumption, kWh/a		



(iii) Over-all Energy consumption in paper machine, stock preparation, chemical preparation and addition plant , finishing house and offline coating plant add (i+ii)

	Qty	Source/ document
LP Steam consumption,t/a		
MP Steam consumption, t/a		
Power consumption, kWh/a		

**A.3 The Information required is shown in the Flow Chart for Wood Based Pulp and Paper Mill**

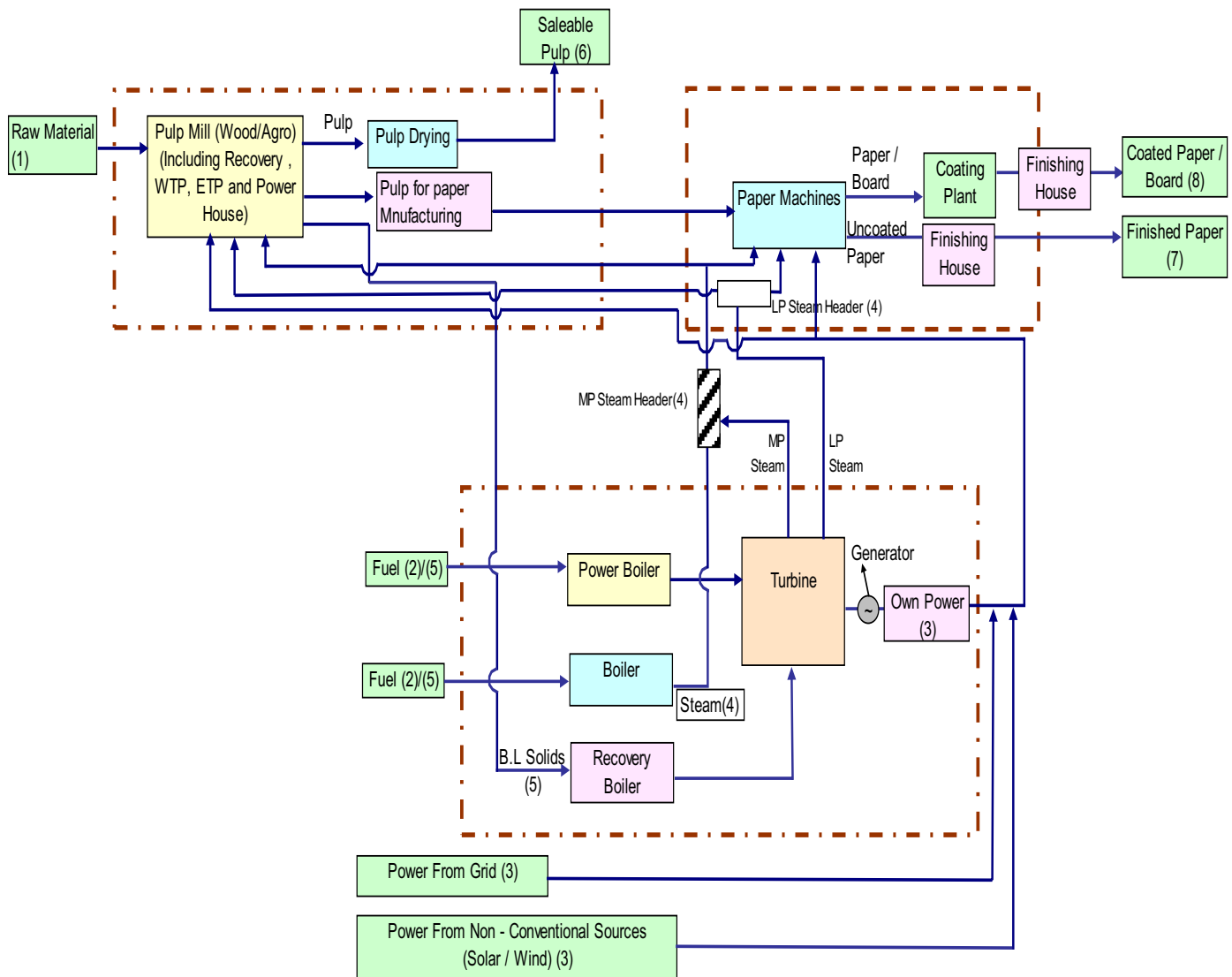

**Figure 20: Ex- GtG boundary and metering details for Wood based Pulp and Paper Mill**



**Table 26: Documents required wood based Pulp and Paper Mills**

S.No.	Details of input and output	Source / Type of document required	Details of the Source / document and frequency
1	Raw Materials	Lab Report	Report on moisture(%), Ash (%) and other analysis of the raw materials used by the mill Frequency: Daily/ weekly/ monthly/ annual lab reports may be produced for different types of raw materials used by the mills.
		Purchase Document From Purchase Department	Purchase documents providing details of raw material purchased by the mill Frequency: Daily/ weekly/ monthly/ annual purchase documents may be produced for purchase of different types of raw materials used by the mills
		Raw Material Consumption Reports	Consumption reports giving details of raw material consumed by the mill. The report may be for raw material chip production, digester loading etc. from the concerned department. Frequency: Daily/ weekly/ monthly/ annual consumption documents may be produced for different types of raw materials used by the mill in chipper / digesters house..
		Annual Report	Annual report showing details of raw materials consumed on annual basis by the mill. Frequency: Annual consumption of raw materials by the mill.
2	Purchased Fuels	Fuel Purchase report/ documents	Purchase documents providing details of fuel purchased by the mill. Frequency: Daily/ weekly/ monthly/ annual purchase documents may be produced for purchase of different types of fuels used by the mills.
		Lab report for moisture and Ash GCV	Lab report on GCV, moisture(%), Ash (%) and other analysis (proximate and ultimate) density etc, of the fuel used by mill. Frequency: Daily/ weekly/ monthly/ annual lab reports may be produced for different types of fuels used by the mills.
		Fuel Consumption Report	Consumption reports giving details of fuel consumed by the mill in boilers, DG sets etc. The consumption report may be from the concerned department showing details of fuel consumption. Frequency: Daily/ weekly/ monthly/ annual fuel consumption documents may be produced for different types of fuels used by the mill in boiler/DG sets etc.
		Annual Report	Annual report showing details of fuels consumed on annual basis by the mill. Frequency: Annual consumption of fuels by the mill.



S.No.	Details of input and output	Source / Type of document required	Details of the Source / document and frequency
3	Power	Electricity Purchased from Grid	Purchased electricity bill from state electricity board providing details of the electricity purchased by the mill. Frequency: monthly/ annual purchased electricity bills may be produced by the mills.
		Own power generation	Details of own power generation from different sources such as turbines(gas, steam etc), DG sets. Frequency: Daily/ weekly/ monthly/ annual own generation reports may be produced by the mills. These reports may be the log sheets/ production reports from power house.
		Production of power from Non Conventional sources, e.g. Solar / wind power	Details of power generation from different Non-conventional sources such as Solar / wind turbines, bio gas etc. Frequency: Daily/ weekly/ monthly/ annual Power generation reports may be produced by the mills. These reports may be the log sheets/ production reports from concerned power houses / departments
		Annual Report	Annual report showing details of Power purchased from grid, own power generation, power from non-conventional sources etc. Frequency: Annual report of power purchased , own generation, generation from non- conventional sources etc.by the mill.
4	Steam	Steam generation by the mill	Details of Steam generation from different boilers, extraction of steam from turbines, steam generation from waste heat recovery and non-conventional sources(Solar steam generators) Frequency: Daily/ weekly/ monthly/ annual steam generation reports may be produced by the mills. These reports may be the log sheets/ production reports for steam generation from boiler house etc.
		Steam consumption by the mill	Details of Steam consumption in different sections of the mill such as pulp mill, chemical recovery, paper machine, power house and other plants of the mill. Frequency: Daily/ weekly/ monthly/ annual steam consumption reports may be produced by the mills. These reports may be the log sheets/ consumption reports for steam consumption by individual section of the mill or power boiler house.
		Annual Reports	Annual report showing details of Steam Generation and consumption from various sources. The generation and consumption of steam may be in individual departments as well as for the whole mill, boilers, extraction steam, steam from non-conventional sources etc. Frequency: Annual report of steam generation and consumption by the mill.



S.No.	Details of input and output	Source / Type of document required	Details of the Source / document and frequency
5	Internally Generated Fuels (Black liquor solids, pith, chipper dust)	Generation report of Black liquor, pith, chipper dust, etc	<p>Details of generation of black liquor , pith , chipper dust or any other combustible waste by the mill from different sections such as chipper house, pulp mill, other plants.</p> <p>Frequency: Daily/ weekly/ monthly/ annual Black liquor, dust etc generation reports may be produced by the mills. These reports may be the log sheets/ production reports for Black liquor and pith generation from boiler house etc.</p>
		Lab reports for GCV, solids, moisture, ash etc.	<p>Lab report on GCV, solids (%) moisture(%), Ash (%) and other analysis (proximate) of the Black liquor, pith, dust etc. used by the mill.</p> <p>Frequency: Daily/ weekly/ monthly/ annual lab reports may be produced for different types of Black liquor, pith, dust etc. used by the mill.</p>
		Annual Report	<p>Annual report showing details of Black liquor generation, dust and pith generation, from various sources such as pulp mill, chippers, etc.</p> <p>Frequency: Annual report of Black liquor, pith and dust generation by the mill.</p>
6	Saleable Pulp	Opening and closing stock of saleable pulp	<p>Documents providing details of opening and closing of saleable pulp records by the mill.</p> <p>Frequency: Daily/ weekly/ monthly/ annual opening and closing records of the saleable pulp stock may be produced for different types of pulps produced by the mill.</p>
		Saleable pulp production	<p>Documents providing details of production of saleable pulp from different raw materials by the mill.</p> <p>Frequency: Daily/ weekly/ monthly/ annual production records/ documents providing details of saleable pulp from different types of raw materials produced by the mill.</p>
		Annual Report	<p>Annual report showing details of saleable pulp production from different raw materials and its consumption etc. Also the annual stock closing and opening of the saleable pulp from annual report may be produced</p> <p>Frequency: Annual report of saleable pulp production, consumption and stock (opening/ closing) by the mill.</p>
7	Uncoated paper/ board, Newsprint, Specialty grade	Opening and closing stock reports	<p>Documents/ records providing details of opening and closing of Uncoated paper / board, Newsprint, Specialty grade paper products by the mill.</p> <p>Frequency: Daily/ weekly/ monthly/ annual opening and closing records of Uncoated paper / board, Newsprint, Specialty grade paper products, produced by the mill.</p>



S.No.	Details of input and output	Source / Type of document required	Details of the Source / document and frequency
		Paper production report / documents	Documents providing details of production of Uncoated paper/board, Newsprint, Specialty grade paper products, produced by the mill  Frequency: Daily/weekly/ monthly/ annual production records/documents providing details of Uncoated paper/board, Newsprint, Specialty grade paper products, produced by the mill.
		Annual Report	Annual report showing details of Uncoated paper / board, Newsprint, Specialty grade paper products, produced by the mill.  Also the annual stock closing and opening of the Uncoated paper / board, Newsprint, Specialty grade paper products, produced by the mill from annual report may be produced  Frequency: Annual report of Uncoated paper / board, Newsprint , Specialty grade paper products, produced and stock (opening/ closing) by the mill.
8	Coated Paper / board	Opening and closing stock reports	Documents/ records providing details of opening and closing of Coated Paper / board by the mill.  Frequency: Daily/ weekly/ monthly/ annual opening and closing records of Coated Paper / board, produced by the mill.
		Paper production report / documents	Documents providing details of production of Coated Paper / board produced by the mill  Frequency: Daily/ weekly/ monthly/ annual production records/ documents providing details of Coated Paper / board produced by the mill.
		Annual Report	Annual report showing details of Coated Paper / board, produced by the mill.  Also the annual stock closing and opening of the Coated Paper / board, produced by the mill from annual report may be produced  Frequency: Annual report of Coated Paper / board, produced and stock (opening/ closing) by the mill.

**B. Agro Based Mills:-**

a. The auditor may collect details required in M&V by mentioning the source and document from where data is collected. Subsequently the data may be verified from the data provided by the DC in pro-forma for

normalization.

- b. The information required is shown in the flow chart for Agro based pulp and paper mill.
- c. List of documents required for various monitoring and verification



**Table 27: General details required in Agro based Pulp and Paper Mills**

**B.1 Raw Material Details**

Type of Agro Paper

Name of the raw material	Moisture, %	Quantity, t/a	Source/ document

Whether Depithing at Mill Site                      Yes / No

**B.2 Depither Details**

Item	Unit	Qty	Source/ document
No. of Depithers	Nos		
Capacity	Tonne/ annum		
Type of depithing,	Wet/ dry		
Moisture	%		
Pith removal	%		

**B.3 AgroPulp Mill (Including Raw material, Pulper, Digester ,WSC, ODL , Recovery, Bleach Plant, WTP, and ETP)**

**i) Pulping Process Used**

Type of pulping	Capacity t/a	Production t/a	Total Yield (Including screening losses)	Source / Document
Chemical				
Semi Chemical				
Chemi Thermo Mechanical				
Other				

**ii) Refining Details**

Items	Unit	Qty	Source / Document
Type of refiners			
Capacity of Refiner, t/a	Tonne/ annum		
Pulp Yield, %	%		



iii) **Extended Delignification (ODL)**

Item	Unit	Qty.	Source / Document
Extended Delignification (ODL)	Yes/No		
Capacity	Tonne/annum		
Date of Installation of ODL Plant	Date		

v) **Bleaching**

Item	Chemical Pulp	Semi Chemical	Chemical Thermo Mechanical Pulp
Type of Bleaching	ECF/conv.	ECF/conv.	ECF/conv.
Sequence Used			
Bleaching Losses %			
Bleached Pulp Yield %			
Brightness of pulp, %			

Item	Date	Source / Document
Date of Installation of ECF Bleach Plant		

vi) **Energy Consumption in Pulp Mill**

Item	Qty	Source/ Document
LP Steam Consumption, t/a		
MP Steam Consumption, t/a		
Power Consumption, kWh/a		

v) **Pulp Dryer**

Sr No	Item	Unit	Qty	Source / Document
1	Capacity	Tonne/annum		
2	Production of salable pulp	Tonne/annum		
3	Energy Consumption in pulp dryer	kcal		
4	LP Steam Consumption	Tonne/annum		
5	MP Steam Consumption	Tonne/annum		
6	Power Consumption	kWh/annum		





vi) **Chemical Recovery**

Sr No	Item	Unit	Data	Source / Document
1	Type of chemical recovery	Conventional/ Non-Conventional		
2	Total Black liquor Solids generated	Tonnes		
3	In Lime Kiln Installed	Yes/No		
4	Date of Installation of Lime Kiln I	Date		
5	Date of Installation of Lime Kiln II	Date		
6	Date of Installation of Lime Kiln III	Date		

vii) **Over-all Energy consumption in pulp mill**

Item	Qty	Source / Document
LP Steam consumption, t/a		
MP Steam consumption, t/a		
Power consumption, kWh/a		

**B.4 Paper Machine (including stock preparation, chemical preparation/addition plant, finishing house)**

(i) **Paper Machine Details**

Number of Paper Machines

Item	PM-1	PM-2	PM-3	PM-4	PM-5	Source/ document
Type of paper machine						
Capacity, t/a						
Type of paper produced						
Production, t/a						
Annual weight average GSM						
<b>Energy Consumption in paper machine (including Stock Preparation , chemical addition and finishing house)</b>						
LP Steam consumption t/a						
MP Steam consumption, t/a						
Power consumption, kWh/a						



(ii) Coating / Value addition

Coating If any

Yes /No

Type of coating

online / offline

Item	Qty	Source/ document
Capacity of offline coating plant, t/a		
Production of coated paper/board, t/a		
LP Steam consumption, t/a		
MP Steam consumption, t/a		
Power consumption, kWh/a		

(iii) Over-all Energy consumption in paper machine, stock preparation, chemical preparation and addition plant, finishing house and offline coating plant add (i+ii)

	Qty	Source/ document
LP Steam consumption, t/a		
MP Steam consumption, t/a		
Power consumption, kWh/a		

**B.5 The Information required is shown in the Flow Chart for Agro Based Pulp and Paper Mill**

Figure 21: Ex- GtG boundary and metering details for Agro based Pulp and Paper Mill

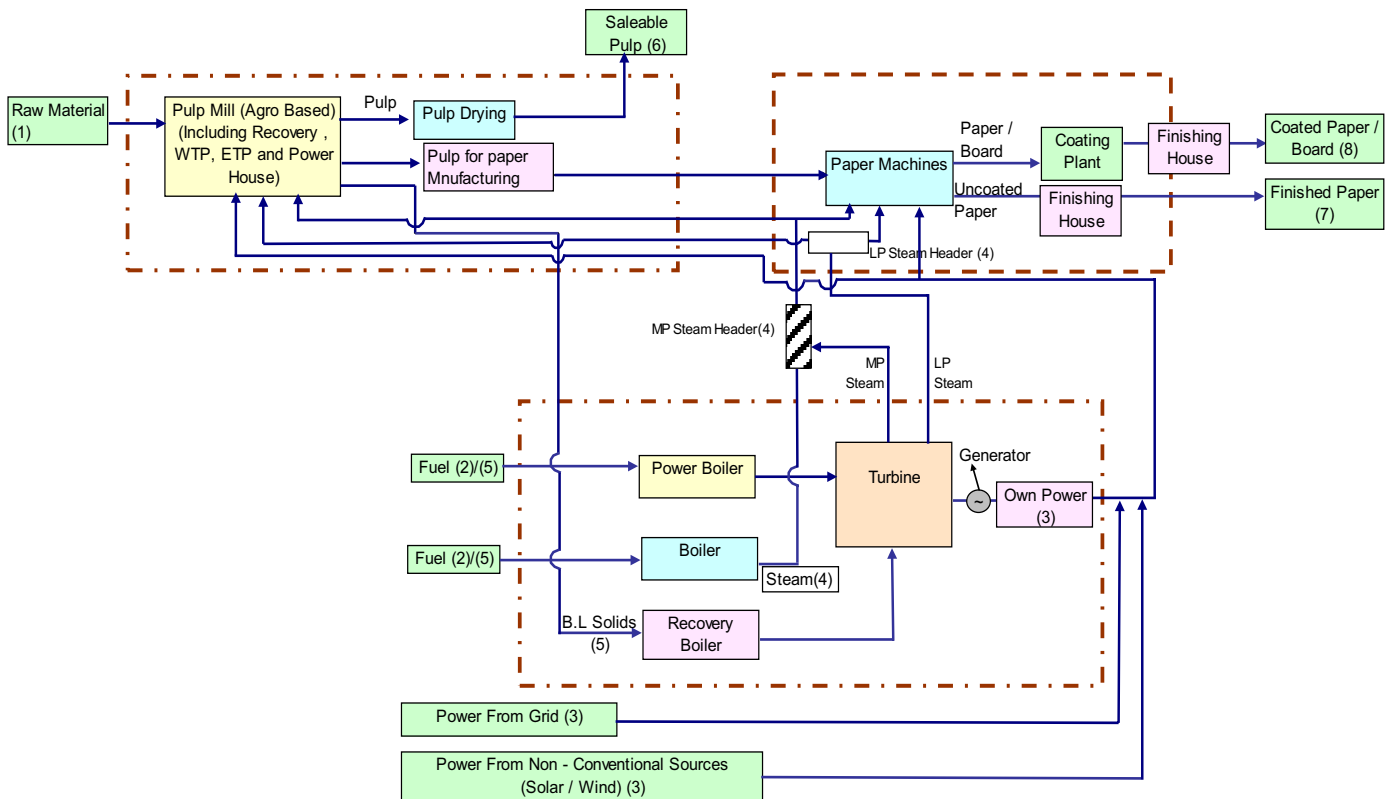



**Table 28: Document required for Agro based Pulp and Paper Mills**

S.No.	Details of input and output	Source / Type of document required	Details of the Source / document and frequency
1	Raw Materials	Lab Report	Report on moisture(%), Ash (%) and other analysis of the raw materials used by the mill  Frequency: Daily/ weekly/ monthly/ annual lab reports may be produced for different types of raw materials used by the mills.
		Purchase Document From Purchase Department	Purchase documents providing details of raw material purchased by the mill  Frequency: Daily/ weekly/ monthly/ annual purchase documents may be produced for purchase of different types of raw materials used by the mills
		Raw Material Consumption Reports	Consumption reports giving details of raw material consumed by the mill. The report may be for raw material chip production, digester loading etc. from the concerned department.  Frequency: Daily/ weekly/ monthly/ annual consumption documents may be produced for different types of raw materials used by the mill in chipper / digesters house..
		Annual Report	Annual report showing details of raw materials consumed on annual basis by the mill.  Frequency: Annual consumption of raw materials by the mill.
2	Purchased Fuels	Fuel Purchase report / documents	Purchase documents providing details of fuel purchased by the mill.  Frequency: Daily/ weekly/ monthly/ annual purchase documents may be produced for purchase of different types of fuels used by the mills.
		Lab report for GCV moisture and Ash	Lab report on GCV, moisture(%), Ash (%) and other analysis (proximate and ultimate) density etc, of the fuel used by mill.  Frequency: Daily/ weekly/ monthly/ annual lab reports may be produced for different types of fuels used by the mills.
		Fuel Consumption Report	Consumption reports giving details of fuel consumed by the mill in boilers, DG sets etc. The consumption report may be from the concerned department showing details of fuel consumption.  Frequency: Daily/ weekly/ monthly/ annual fuel consumption documents may be produced for different types of fuels used by the mill in boiler/DG sets etc.
		Annual Report	Annual report showing details of fuels consumed on annual basis by the mill.  Frequency: Annual consumption of fuels by the mill.



S.No.	Details of input and output	Source / Type of document required	Details of the Source / document and frequency
3	Power	Electricity Purchased from Grid	Purchased electricity bill from state electricity board providing details of the electricity purchased by the mill. Frequency: monthly/ annual purchased electricity bills may be produced by the mills.
		Own power generation	Details of own power generation from different sources such as turbines(gas, steam etc), DG sets. Frequency: Daily/ weekly/ monthly/ annual own generation reports may be produced by the mills. These reports may be the log sheets/ production reports from power house.
		Production of power from Non Conventional sources, e.g. Solar / wind power	Details of power generation from different Non-conventional sources such as Solar / wind turbines, bio gas etc. Frequency: Daily/ weekly/ monthly/ annual Power generation reports may be produced by the mills. These reports may be the log sheets/ production reports from concerned power houses / departments
		Annual Report	Annual report showing details of Power purchased from grid, own power generation, power from non-conventional sources etc. Frequency: Annual report of power purchased , own generation, generation from non- conventional sources etc.by the mill.
4	Steam	Steam generation by the mill	Details of Steam generation from different boilers, extraction of steam from turbines, steam generation from waste heat recovery and non-conventional sources(Solar steam generators) Frequency: Daily/ weekly/ monthly/ annual steam generation reports may be produced by the mills. These reports may be the log sheets/ production reports for steam generation from boiler house etc.
		Steam consumption by the mill	Details of Steam consumption in different sections of the mill such as pulp mill, chemical recovery, paper machine, power house and other plants of the mill. Frequency: Daily/ weekly/ monthly/ annual steam consumption reports may be produced by the mills. These reports may be the log sheets/consumption reports for steam consumption by individual section of the mill or power boiler house.
		Annual Reports	Annual report showing details of Steam Generation and consumption from various sources. The generation and consumption of steam may be in individual departments as well as for the whole mill, boilers, extraction steam, steam from non-conventional sources etc. Frequency: Annual report of steam generation and consumption by the mill



S.No.	Details of input and output	Source / Type of document required	Details of the Source / document and frequency
5	Internally Generated Fuels (Black liquor solids, pith , chipper dust)	Generation report of Black liquor, pith, chipper dust, etc	<p>Details of generation of black liquor , pith , chipper dust or any other combustible waste by the mill from different sections such as chipper house, pulp mill, other plants.</p> <p>Frequency: Daily/ weekly/ monthly/ annual Black liquor, dust etc generation reports may be produced by the mills. These reports may be the log sheets/ production reports for Black liquor and pith generation from boiler house etc.</p>
		Lab reports for GCV, solids, moisture, ash etc.	<p>Lab report on GCV, solids (%) moisture(%), Ash (%) and other analysis (proximate) of the Black liquor, pith, dust etc. used by the mill.</p> <p>Frequency: Daily/ weekly/ monthly/ annual lab reports may be produced for different types of Black liquor, pith, dust etc. used by the mill.</p>
		Annual Report	<p>Annual report showing details of Black liquor generation, dust and pith generation, from various sources such as pulp mill, chippers, etc.</p> <p>Frequency: Annual report of Black liquor, pith and dust generation by the mill.</p>
6	Saleable Pulp	Opening and closing stock of saleable pulp	<p>Documents providing details of opening and closing of saleable pulp records by the mill.</p> <p>Frequency: Daily/ weekly/ monthly/ annual opening and closing records of the saleable pulp stock may be produced for different types of pulps produced by the mill.</p>
		Saleable pulp production	<p>Documents providing details of production of saleable pulp from different raw materials by the mill.</p> <p>Frequency: Daily/ weekly/ monthly/ annual production records/ documents providing details of saleable pulp from different types of raw materials produced by the mill.</p>
		Annual Report	<p>Annual report showing details of saleable pulp production from different raw materials and its consumption etc. Also the annual stock closing and opening of the saleable pulp from annual report may be produced</p> <p>Frequency: Annual report of saleable pulp production, consumption and stock (opening/ closing) by the mill.</p>
7	Uncoated paper / board, Newsprint , Specialty grade	Opening and closing stock reports	<p>Documents/ records providing details of opening and closing of Uncoated paper / board, Newsprint , Specialty grade paper products by the mill.</p> <p>Frequency: Daily/ weekly/ monthly/ annual opening and closing records of Uncoated paper / board, Newsprint , Specialty grade paper products, produced by the mill.</p>



S.No.	Details of input and output	Source / Type of document required	Details of the Source / document and frequency
		Paper production report / documents	Documents providing details of production of Uncoated paper/board, Newsprint, Specialty grade paper products, produced by the mill  Frequency: Daily/ weekly/ monthly/ annual production records/ documents providing details of Uncoated paper / board, Newsprint , Specialty grade paper products, produced by the mill.
		Annual Report	Annual report showing details of Uncoated paper / board, Newsprint, Specialty grade paper products, produced by the mill.  Also the annual stock closing and opening of the Uncoated paper/board, Newsprint, Specialty grade paper products, produced by the mill from annual report may be produced  Frequency: Annual report of Uncoated paper / board, Newsprint , Specialty grade paper products, produced and stock (opening/ closing) by the mill.
8	Coated Paper / board	Opening and closing stock reports	Documents/ records providing details of opening and closing of Coated Paper / board by the mill.  Frequency: Daily/ weekly/ monthly/ annual opening and closing records of Coated Paper / board, produced by the mill.
		Paper production report / documents	Documents providing details of production of Coated Paper / board produced by the mill  Frequency: Daily/ weekly/ monthly/ annual production records/ documents providing details of Coated Paper / board produced by the mill.
		Annual Report	Annual report showing details of Coated Paper / board, produced by the mill.  Also the annual stock closing and opening of the Coated Paper / board, produced by the mill from annual report may be produced  Frequency: Annual report of Coated Paper / board, produced and stock (opening/ closing) by the mill.

### C. RCF Based Mills:-

- a. The auditor may collect details required in M&V format) by mentioning the source and document from where data is collected. Subsequently the data may be verified from the, data provided by the DC in pro-forma for normalization.
- b. The information required is shown in the flow chart for RCF based pulp and paper mill.
- c. List of documents required for various monitoring and verification



**Table 29: General details required in RCF based Pulp and Paper Mills**

**A.1 Material Details**

Type of Waste Paper

Name of the raw material	Moisture, %	Quantity, t/a	Source/ document

**A.2 RCF Pulp Mill (Including Pulper, Pulp Cleaning and Screening, Deinking, Bleaching, WTP, and ETP)**

**i) Pulper / Pulp Cleaning and Screening Process Used**

No. of Unit	Capacity t/a	Production t/a	Source / Document
Pulper			
HD Cleaner			
Screening			
Cleaning and screening rejects, t/a			
No. of Deinking loops			

**ii) Deinking / Bleach Process**

Item	Qty.	Source / Document
Capacity, t/a		
Pulp yield, %		
Fibre Loss, %		
Ink removal Efficiency, %		
Bleaching Stages Yes/No		
Bleaching losses, t/a		

**iii) Refining**

Item	1	2	3	Source / Document
Type of Refiners				
No. of Refiners				
Initial Pulp Freeness oSR /CSF				
Final Freeness oSR /CSF				



**iv) Energy Consumption in Pulp Mill**

Item	Qty	Source / Document
LP Steam consumption, t/a		
MP Steam consumption, t/a		
Power consumption, kWh/a		

**v) Pulp Dryer**

Sr No	Item	Unit	Qty	Source / Document
1	Capacity	Tonne/annum		
2	Production of salable pulp, t/a	Tonne/annum		
3	Energy Consumption in pulp dryer	kcal		
4	LP Steam Consumption	Tonne/annum		
5	MP Steam Consumption	Tonne/annum		
6	Power Consumption	kWh/annum		

**vi) Over-all Energy consumption in pulp mill**

Item	Qty	Source / Document
LP Steam consumption, t/a		
MP Steam consumption, t/a		
Power consumption, kWh/a		

**A.3 Paper Machine (including stock preparation, chemical preparation / addition plant, finishing house)**

**(i) Paper Machine Details**

Number of Paper Machines

Item	PM-1	PM-2	PM-3	PM-4	PM-5	Source/ document
Type of paper machine						
Capacity, t/a						
Type of paper produced						
Production, t/a						
Annual weight average GSM						
<b>Energy Consumption in paper machine (including Stock Preparation , chemical addition and finishing house)</b>						
LP Steam consumption t/a						
MP Steam consumption, t/a						
Power consumption, kWh/a						





**(ii) Coating/ Value addition**

Coating If any  
Type of coating

Yes /No  
online / offline

Item	Qty	Source/ document
Capacity of offline coating plant, t/a		
Production of coated paper/board, t/a		
LP Steam consumption, t/a		
MP Steam consumption, t/a		
Power consumption, kWh/a		

**(iii) Over-all Energy consumption in paper machine,stock preparation, chemical preparation and addition plant, finishing house and offline coating plant add (i+ii)**

	Qty	Source/ document
LP Steam consumption, t/a		
MP Steam consumption, t/a		
Power consumption, kWh/a		

A.4 The Information required is shown in the Flow Chart for RCF Based Pulp and Paper Mill

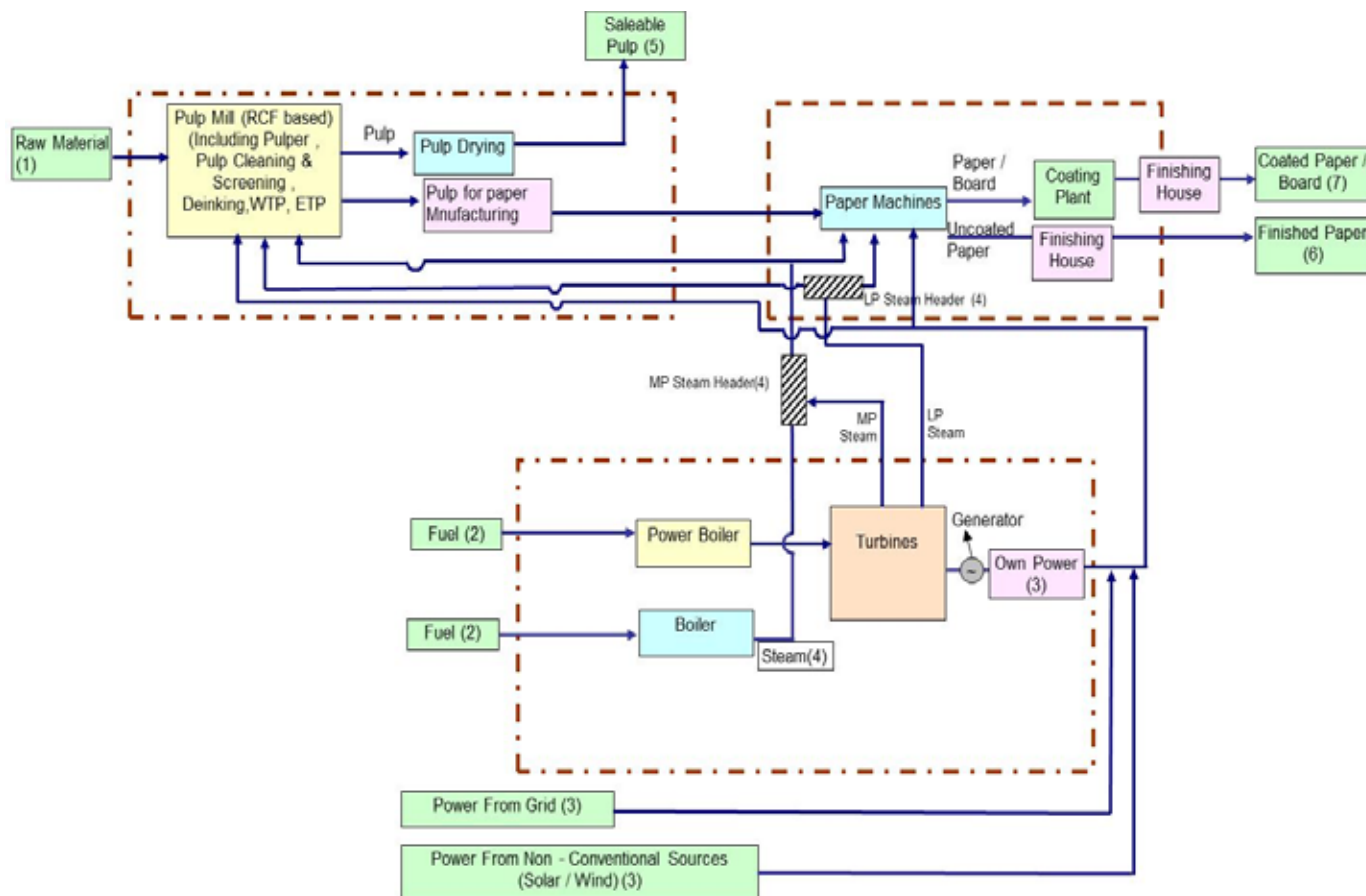



**Table 30: Documents required in RCF based Pulp and Paper**

S.No.	Details of input and output	Source / Type of document required	Details of the Source / document and frequency
1	Raw Materials	Lab Report	Report on moisture(%), Ash (%) and other analysis of the raw materials used by the mill Frequency: Daily/ weekly/ monthly/ annual lab reports may be produced for different types of raw materials used by the mills.
		Purchase Document From Purchase Department	Purchase documents providing details of raw material purchased by the mill Frequency: Daily/ weekly/ monthly/ annual purchase documents may be produced for purchase of different types of raw materials used by the mills
		Raw Material Consumption Reports	Consumption reports giving details of raw material consumed by the mill. The report may be for raw material chip production, digester loading etc. from the concerned department. Frequency: Daily/ weekly/ monthly/ annual consumption documents may be produced for different types of raw materials used by the mill in chipper / digesters house..
		Annual Report	Annual report showing details of raw materials consumed on annual basis by the mill. Frequency: Annual consumption of raw materials by the mill.
2	Purchased Fuels	Fuel Purchase report / documents	Purchase documents providing details of fuel purchased by the mill. Frequency: Daily/ weekly/ monthly/ annual purchase documents may be produced for purchase of different types of fuels used by the mills.
		Lab report for moisture and Ash GCV	Lab report on GCV, moisture(%), Ash (%) and other analysis (proximate and ultimate) density etc, of the fuel used by mill. Frequency: Daily/ weekly/ monthly/ annual lab reports may be produced for different types of fuels used by the mills.
		Fuel Consumption Report	Consumption reports giving details of fuel consumed by the mill in boilers, DG sets etc. The consumption report may be from the concerned department showing details of fuel consumption. Frequency: Daily/ weekly/ monthly/ annual fuel consumption documents may be produced for different types of fuels used by the mill in boiler/DG sets etc.
		Annual Report	Annual report showing details of fuels consumed on annual basis by the mill. Frequency: Annual consumption of fuels by the mill.



S.No.	Details of input and output	Source / Type of document required	Details of the Source / document and frequency
3	Power	Electricity Purchased from Grid	Purchased electricity bill from state electricity board providing details of the electricity purchased by the mill. Frequency: monthly/ annual purchased electricity bills may be produced by the mills.
		Own power generation	Details of own power generation from different sources such as turbines(gas, steam etc), DG sets. Frequency: Daily/ weekly/ monthly/ annual own generation reports may be produced by the mills. These reports may be the log sheets/ production reports from power house.
		Production of power from Non Conventional sources, e.g. Solar / wind power	Details of power generation from different Non-conventional sources such as Solar / wind turbines, bio gas etc. Frequency: Daily/ weekly/ monthly/ annual Power generation reports may be produced by the mills. These reports may be the log sheets/ production reports from concerned power houses / departments
		Annual Report	Annual report showing details of Power purchased from grid, own power generation, power from non-conventional sources etc. Frequency: Annual report of power purchased , own generation, generation from non- conventional sources etc.by the mill.
4	Steam	Steam generation by the mill	Details of Steam generation from different boilers, extraction of steam from turbines, steam generation from waste heat recovery and non-conventional sources(Solar steam generators) Frequency: Daily/ weekly/ monthly/ annual steam generation reports may be produced by the mills. These reports may be the log sheets/ production reports for steam generation from boiler house etc.
		Steam consumption by the mill	Details of Steam consumption in different sections of the mill such as pulp mill, chemical recovery , paper machine, power house and other plants of the mill. Frequency: Daily/ weekly/ monthly/ annual steam consumption reports may be produced by the mills. These reports may be the log sheets/ consumption reports for steam consumption by individual section of the mill or power boiler house.
		Annual Reports	Annual report showing details of Steam Generation and consumption from various sources. The generation and consumption of steam may be in individual departments as well as for the whole mill, boilers, extraction steam, steam from non-conventional sources etc. Frequency: Annual report of steam generation and consumption by the mill



S.No.	Details of input and output	Source / Type of document required	Details of the Source / document and frequency
5	Saleable Pulp	Opening and closing stock of saleable pulp	Documents providing details of opening and closing of saleable pulp records by the mill. Frequency: Daily/ weekly/ monthly/ annual opening and closing records of the saleable pulp stock may be produced for different types of pulps produced by the mill.
		Saleable pulp production	Documents providing details of production of saleable pulp from different raw materials by the mill. Frequency: Daily/ weekly/ monthly/ annual production records/ documents providing details of saleable pulp from different types of raw materials produced by the mill.
		Annual Report	Annual report showing details of saleable pulp production from different raw materials and its consumption etc. Also the annual stock closing and opening of the saleable pulp from annual report may be produced Frequency: Annual report of saleable pulp production, consumption and stock (opening/ closing) by the mill.
6	Uncoated paper / board, Newsprint, Specialty grade	Opening and closing stock reports	Documents/ records providing details of opening and closing of Uncoated paper / board, Newsprint , Specialty grade paper products by the mill. Frequency: Daily/ weekly/ monthly/ annual opening and closing records of Uncoated paper / board, Newsprint, Specialty grade paper products, produced by the mill.
		Paper production report / documents	Documents providing details of production of Uncoated paper/board, Newsprint, Specialty grade paper products, produced by the mill Frequency: Daily/ weekly/ monthly/ annual production records/ documents providing details of Uncoated paper / board, Newsprint , Specialty grade paper products, produced by the mill.
		Annual Report	Annual report showing details of Uncoated paper / board, Newsprint, Specialty grade paper products, produced by the mill. Also the annual stock closing and opening of the Uncoated paper / board, Newsprint , Specialty grade paper products, produced by the mill from annual report may be produced Frequency: Annual report of Uncoated paper / board, Newsprint , Specialty grade paper products, produced and stock (opening/ closing) by the mill.



S.No.	Details of input and output	Source / Type of document required	Details of the Source / document and frequency
7	Coated Paper / board	Opening and closing stock reports	Documents/ records providing details of opening and closing of Coated Paper / board by the mill. Frequency: Daily/ weekly/ monthly/ annual opening and closing records of Coated Paper / board, produced by the mill.
		Paper production report / documents	Documents providing details of production of Coated Paper / board produced by the mill Frequency: Daily/ weekly/ monthly/ annual production records/ documents providing details of Coated Paper / board produced by the mill.
		Annual Report	Annual report showing details of Coated Paper / board, produced by the mill. Also the annual stock closing and opening of the Coated Paper / board, produced by the mill from annual report may be produced Frequency: Annual report of Coated Paper / board, produced and stock (opening/ closing) by the mill.

### 7.7. Annexure VII: Textile

1. Section wise Energy metering (Electrical and Thermal) is required for making Equivalent Product in Textile sub-sectors. Proper calculation document should be maintained, if energy figures are arrived by calculation method.
2. SCADA Screen shot is required for Major and Auxilliary systems.
3. Inclusions and Exclusion should be clearly marked in the Gate to Gate Boundary Diagram.
4. It is essential to express quantities of different product types in a single unit for calculation of specific energy consumption from Gram per Linear Meter (GLM) or Gram per Square Meter (GSM). DC to furnish back up calculation of conversion to EmAEA.
5. Mass balance is required to be furnished in the verification report.
6. EmAEA is advised to convert other special

product or value added product in to the major equivalent product through Energy Consumption and the calculation is to be included in the verification report

#### 7. Spinning Sub-Sector

- a. Count of Yarn is one of the important parameter. Change in the count of the yarn may result in the change in the UKG of the plant. So normalization for count of yarn is important. Hence, all the product needs to be converted to 40s count s per SITRA guidelines for UKG calculation at TFO - AutoConer output. The calculation for conversion shall be an integral part of the verification report.
- b. The open end yarn to be converted to 10s count for UKG calculation.
- c. Section wise energy consumption to be provided for backup calculation as per sample table. EmAEA is required to insert or delete the section as per the requirement



**Table 31: Section wise Energy Consumption**

Sr No	Item	Electrical SEC (kwh/kg)	Thermal SEC (kcal/kg)	Remarks
1	Blow Room			
2	Carding			
3	Combing			
4	Draw Frame			
5	Speed Frame			
6	Ring Frame			
7	Winding			
8	TFO			
9	AutoConer			
10	Doubling			
11	Singing and Sizing			
12	Humidification			
13	Lighting			
14	Utilities			
15	Misc Others			

- d. The calculation used to convert other type of yarn (Like PV, Worsted etc) into the singular yarn in the baseline year will remain same in the assessment year. EmAEA is advised to use the same formulae as per Baseline Year Report.
- e. All special product yarn (Melange/ Fibre dyed Yarns, High value blended yarns mixed with Wool, Silk, Modal, Nylon, etc, Slub Yarns, Compact yarns, TFO doubled yarns, Jaspe yarns, Jaspe slub yarns, Nep effect yarns) needs to be converted in to single major product. The conversion formulae for baseline and assessment year will be same.
- f. Production and capacity to be equated w.r.t. the Nos, speed, weight and running hours of Ring Frame and Autoconer.
- g. Mention clear bifurcation of energy in Major Product (GtG boundary as per PAT) and other products as per Boundary Limit Example.

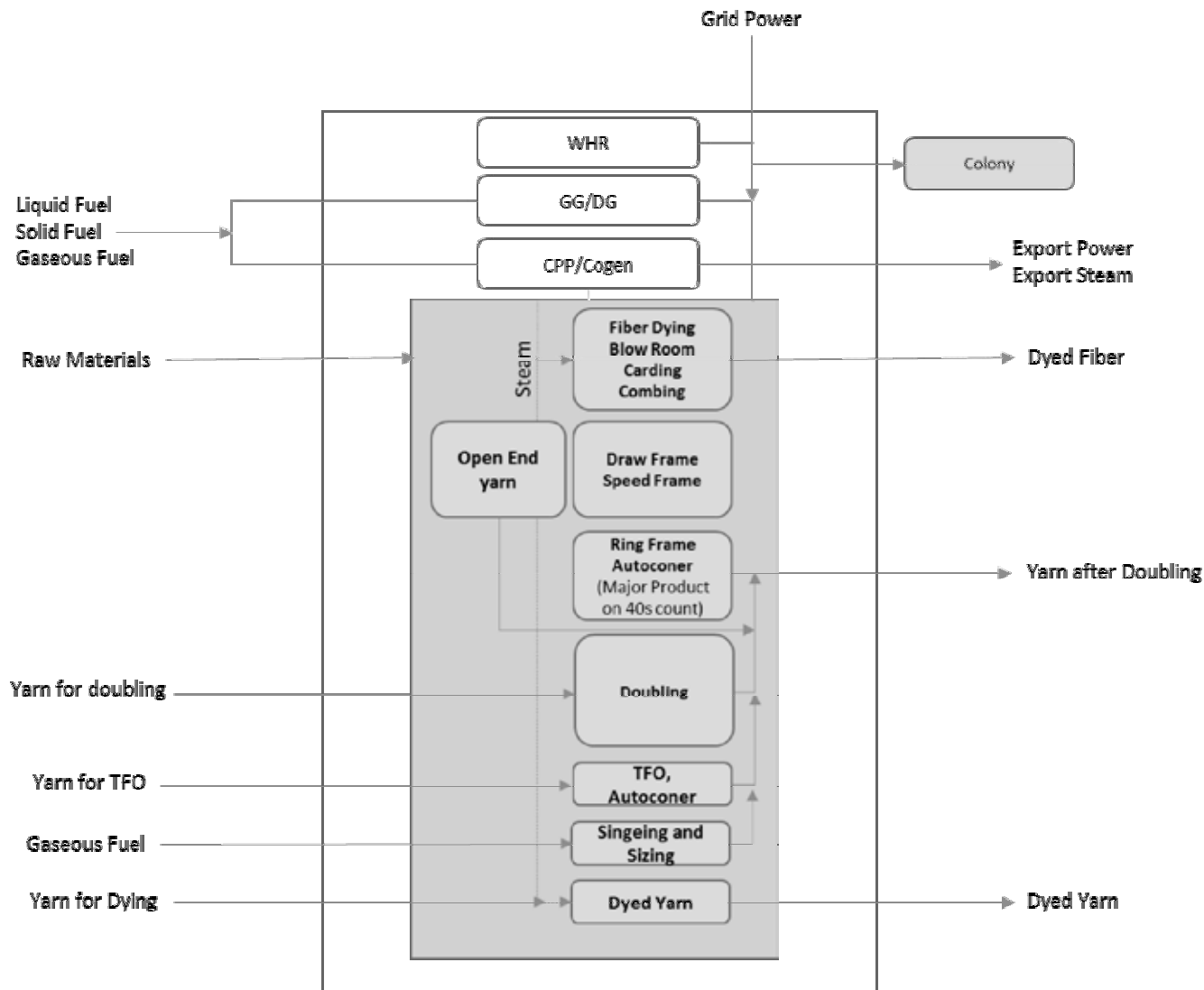

Figure 22: Ex- GtG boundary for Textile (Spinning sub sector)

8. Composite and Processing Sub sector

a. There are five finished product defined in the Composite sub-group, all other special or value added product shall be converted into either of these five major products through energy consumption of making those special or value added product. The calculation of conversion is to be included in the verification report of EmAEA.

The final five finished products in the Composite sub group are:

- i. Cotton
  - ii. Polyester Cotton
  - iii. Lycra
  - iv. Non Cellulosic Product (100% Synthetic)
  - v. Wool based product
- b. Picks as standard for taking production in case of Weaving. In case of weaving, in order to streamline products of all the DCs 60 PPI (Picks per Inch) as standard value and DCs should



convert their weaving production at different picks to production at 60 PPI. EmAEA to include the conversion calculation in the verification report.

- c. Similarly for Knitting, conversion factors shall be in terms of Wales on weight basis.
- d. Mass and Energy balance calculation

is required to be included in the verification report by EmAEA

- e. Steam balance diagram is required to be included in the verification report by EmAEA
- f. Section wise Specific Energy Consumption is required to be specified as per table below

**Table 32: Section wise Energy Consumption**

Sr No	Item	Electrical SEC (kwh/kg)	Thermal SEC (kcal/kg)	Remarks
<b>Spinning</b>				
1	Blow Room			
2	Carding			
3	Combing			
4	Draw Frame			
5	Speed Frame			
6	Ring Frame			
7	Winding			
8	TFO			
9	AutoConer			
10	Doubling			
11	Singing and Sizing			
<b>Knitting/Weaving</b>				
1	Wrapping			
2	Sizing			
3	Knotting			
4	Weaving			
<b>Processing</b>				
1	Singeing			
2	Desizing			
3	Mercerizing			
4	Bleaching			
5	Sueding			
6	Dying			
7	Printing			
<b>Misc and Others</b>				
1	Humidification			
2	Lighting			
3	Utilities			
4	Others			

EmAEA is required to add the section as per the requirement and need





- g. Demarcation of plant boundary is required with clear understanding of raw material input, Energy input, Power Import/Export, Intermediary product Import/Export, Colony

Power, Construction/Others Power, Power supplied to other Ancillary unit outside the plant boundary. A typical sample of Plant boundary condition is represented below

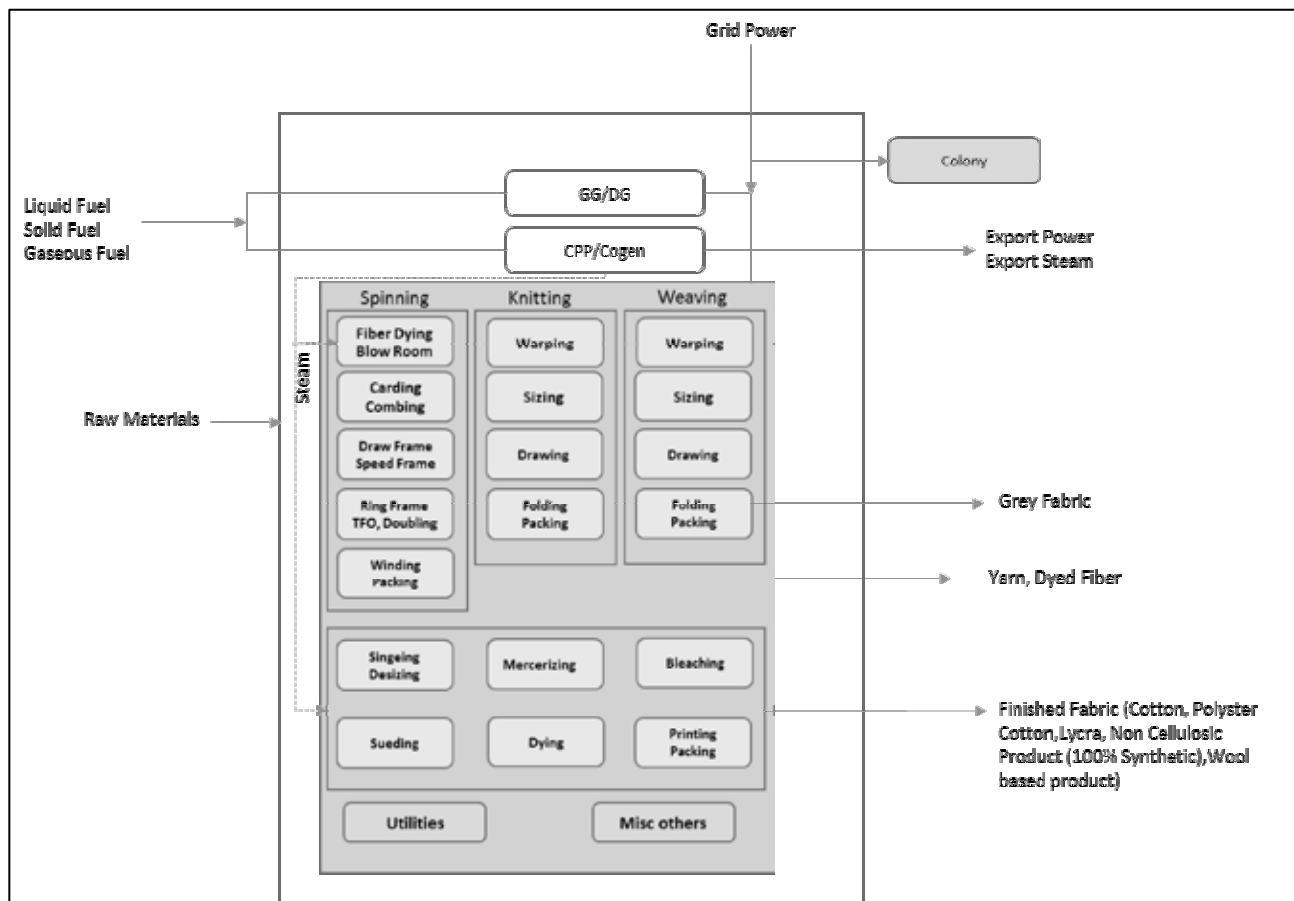

Figure 23: Ex- GtG boundary for Textile ( Composite/ Processing sub sector)

- 9. Fiber Sub-Sector
  - a. Section wise production and Energy performance is required for each Fiber Product
  - b. The Products and sections are different in Fiber sub-sector, hence the Pro-forma of the subsector specify the major product and other Products from 1-5.
  - c. EmAEA to specify the product details with sectional Process Flow Diagram in the verification report.
  - d. Mass balance calculation w.r.t. input raw material and output product with conversion factor is required to be produced
  - e. Fuel used as raw material should not be considered from the input energy and reported in the verification report by EmAEA
  - f. DC has to submit weighted average denier value for their products. Plant has to submit production value in single denier by converting all the denier value



- g. DCs have to convert all of their products in single major product equivalent by taking ratio of the SEC of the other products to the main product
- h. EmAEA to include the details of major products and other products as mentioned in Pro-forma as per following table

**Table 33: Product Name in Fiber Sun-sector**

Sr No	Item	Name	Unit	Remarks
1	Raw Material			
2	Major Product			
3	Product 1			
4	Product 2			
5	Product 3			
6	Product 4			
7	Product 5			
8	Denier			

- i. Steam Balance Diagram of the Plant from Steam generation to Steam consumption is required to be included in the verification report
- j. Product wise, sectional (Sub Process) yearly Thermal and Electrical Energy details is required as per following sample table for Product 1

**Table 34: Section wise Energy Consumption**

Sr No	Item	Electrical SEC (kwh/kg)	Thermal SEC (kcal/kg)	Remarks
1	Polymerisation Process			
2	Spinning Process			
3	Draw line Process			
4	Utilities			
5	Misc Others			

- k. Boundary Condition  
Mention clear bifurcation of energy in Major Product (GtG boundary as per PAT) and other products as per Boundary Limit Example

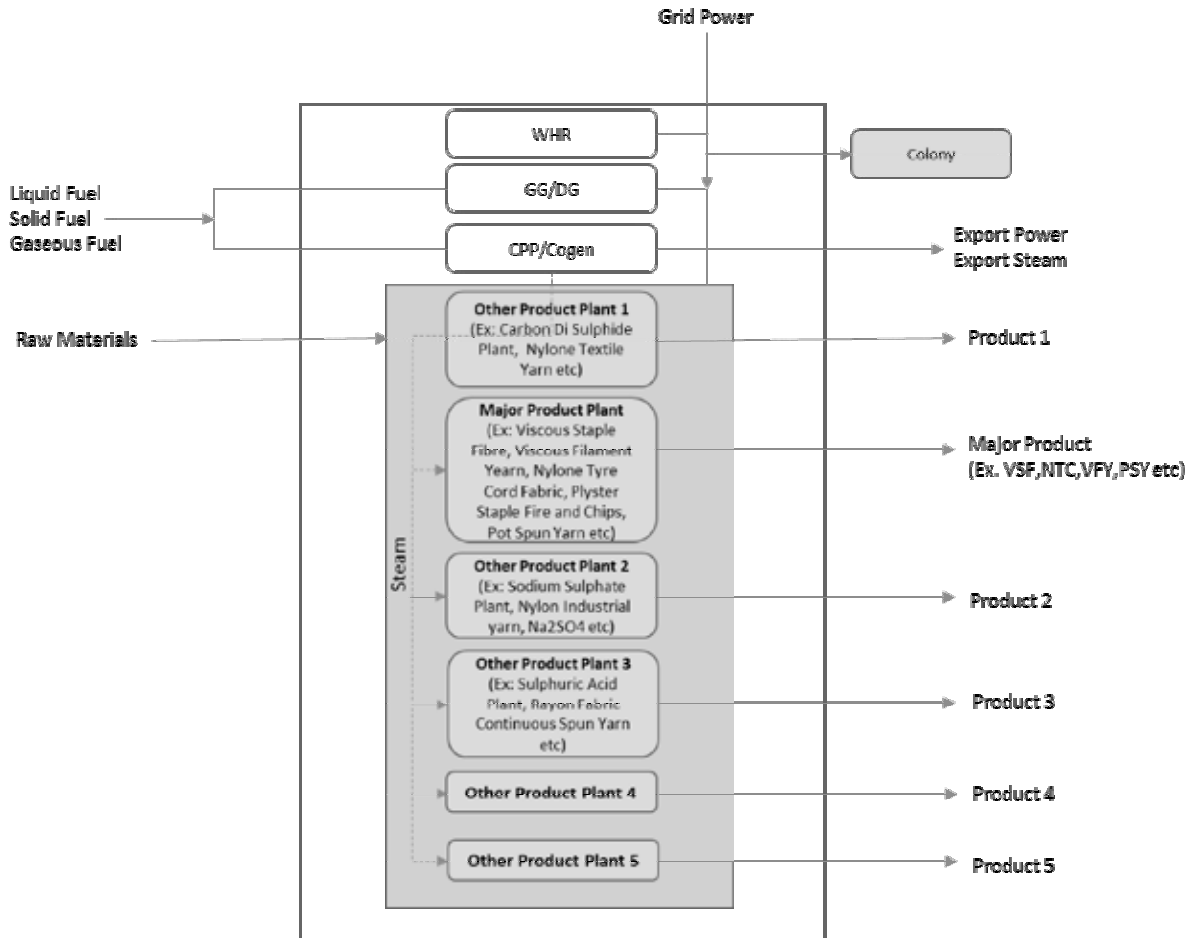

Figure 24: Ex- GtG boundary for Textile (Fiber) Sub- sector

## 7.8. Annexure VIII: Chlor Alkali

### 1. Section wise Details

Section wise Specific Power consumption

and Specific Thermal consumption shall be specified and provided to EmAEA as per following format. EmAEA can add section if required

Table 35: Section wise Energy details

Sr No	Section	SPC kwh/tonne	SEC kcal/kg	Remarks
1	Primary Brine Plant.			
2	Secondary Brine Plant.			
3	Membrane Cell Plant.			
4	Chlorine / Hydrogen Treatment Plant			
5	HCl / Sodium Hypo Plants.			
6	Caustic Concentration and evaporation units.			
7	Utilities Plant.			
8	Waste Water Treatment Plant.			



2. Membrane Change verification: Details regarding membrane change for each cell shall be provided along with the membrane configuration
3. Maximum allowable capacity of chlorine storage in the DC shall be specified and provided to the EmAEA
4. Cathode- Anode coating verification: Details regarding Cathode- Anode coating shall be provided along with the membrane configuration
5. EmAEA shall ensure and verify production of Caustic Soda lye (49% concentration) and Hydrogen as per quantity of Chlorine produced during the electrolysis process. EmAEA shall also ensure that these productions should not exceed the stoichiometric limit
6. If a captive power plant or cogeneration plant caters to two or more DCs for the electricity and/or steam requirements. In such scenario, each DC shall consider such captive power plant or cogeneration plant in its boundary and energy consumed by such captive power plant or cogeneration plant shall be included in the total energy consumption. However, electricity in terms of calorific value (as per actual heat rate) and steam in terms of calorific value (as per steam enthalpy) exported to other plants shall be subtracted from the total energy consumption.
7. Boundary Condition  
Mention clear bifurcation of energy in Caustic Soda plant (GtG boundary as per PAT) and other products as per Boundary Limit Example

Figure 25: Ex- GtG boundary for Chlor-Alkali sector

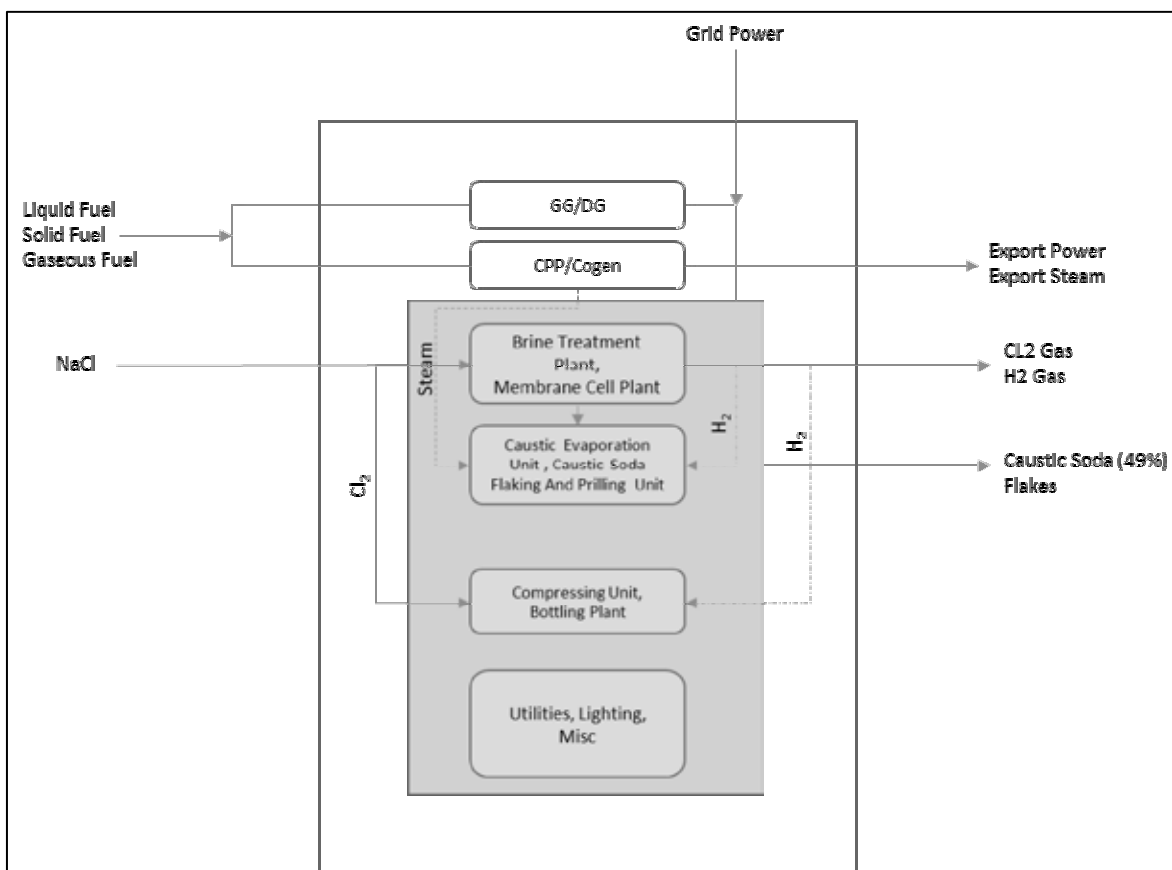

For all practical and legal purposes in connection with M&V guidelines, the English version of the notified PAT rules 2012 and EC Act 2001 will be considered as final.





## **Bureau of Energy Efficiency**

4th Floor, Sewa Bhawan

R.K.Puram, New Delhi - 110 066 (India)

Telephone: +91 11 26179699

Fax: +91 11 26178352

[www:beeindia.in](http://www:beeindia.in)